



# END SUCTION PUMP LEK SERIES



# LEK

## End Suction Pump



### Application

- Water supply and drainage
- HVAC and Cooling Tower
- Marine-Ballasting & Bilge
- Booster and Pressurization Set
- Agriculture irrigation

### Design & Structure

- Design: Compliant with EN733 Standard
- Structure: Horizontal, Axial End-Suction, Single-Stage, Single Suction, Volute Casing, Back pull-out
- Energy Conservation, meets Europe MEI4.0
- DN: 32-350 mm
- Double angular contact bearings for better thrust condtions.

### Working Conditions

- Conveying medium: Low viscosity, non-inflammable and non-explosive liquids not containing solid particles or fibers
- Speed: 1450/2900 rpm at 50 Hz
- Flow range: 4- 1440 m<sup>3</sup>/h
- Head range: 3- 150 m
- Max. Liquid temperature: 85°C (120 °C on request)
- Liquid pH value: 4 - 10
- Max. operation pressure: 10 bar, 16bar on request

### Identification Codes

**LEK - 50 - 32 - 260 / 330 - 4**

Number of Motor Poles

Impeller Actual Diameter (mm)

Impeller Nominal Diameter(mm)

Outlet Diameter (mm)

Inlet Diameter (mm)

LEO End Suction Pump

## Material Table

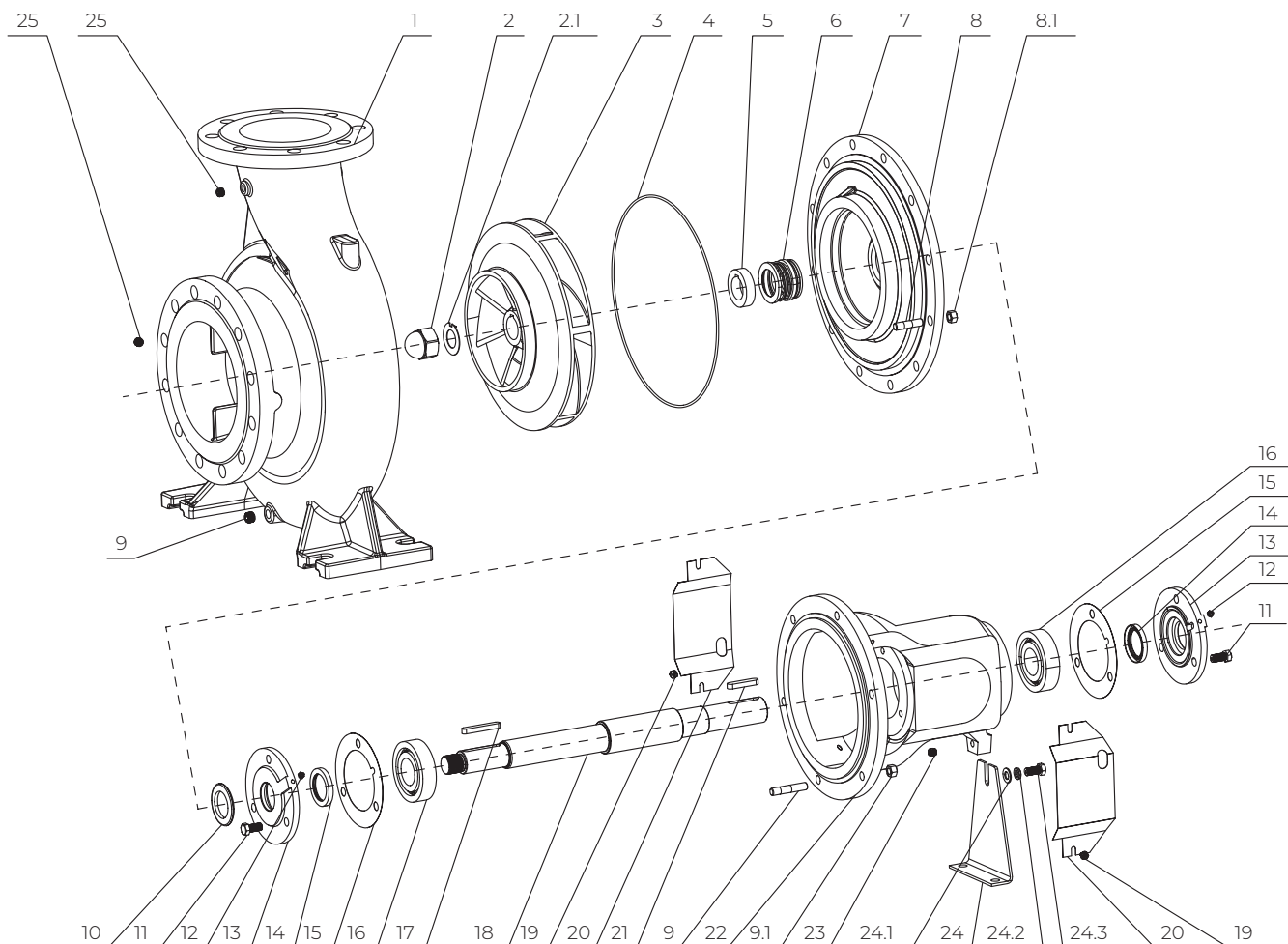

No.	Part
1	Pump body
2	Impeller Nut
2.1	Lock Washer
3	Impeller
4	O-ring
5	Packing Sleeve
6	mechanical seal
7	Casing cover
8	Stud Bolt
8.1	Nut

No.	Part
9	Plug
10	Deflector Ring
11	Screw Bolt
12	Oil Cup
13	Bearing Cover
14	Skeleton Oil Seal
15	Gland cover
16	Bearing
17	Key
18	shaft

No.	Part
19	Screw
20	Guard
21	Key
22	Frame Assembly
23	Plug
24	Bracket
24.1	Washer
24.2	Washer
24.3	Screw Bolt
25	Plug

### Characteristic Curves

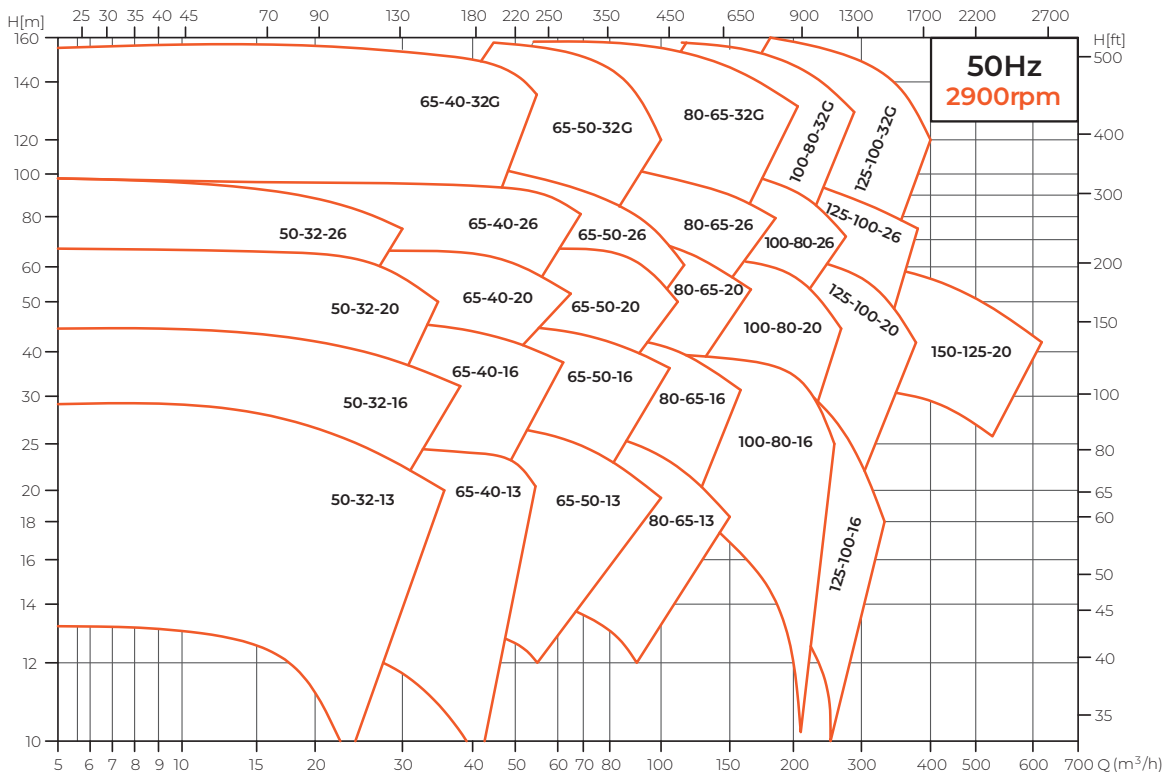
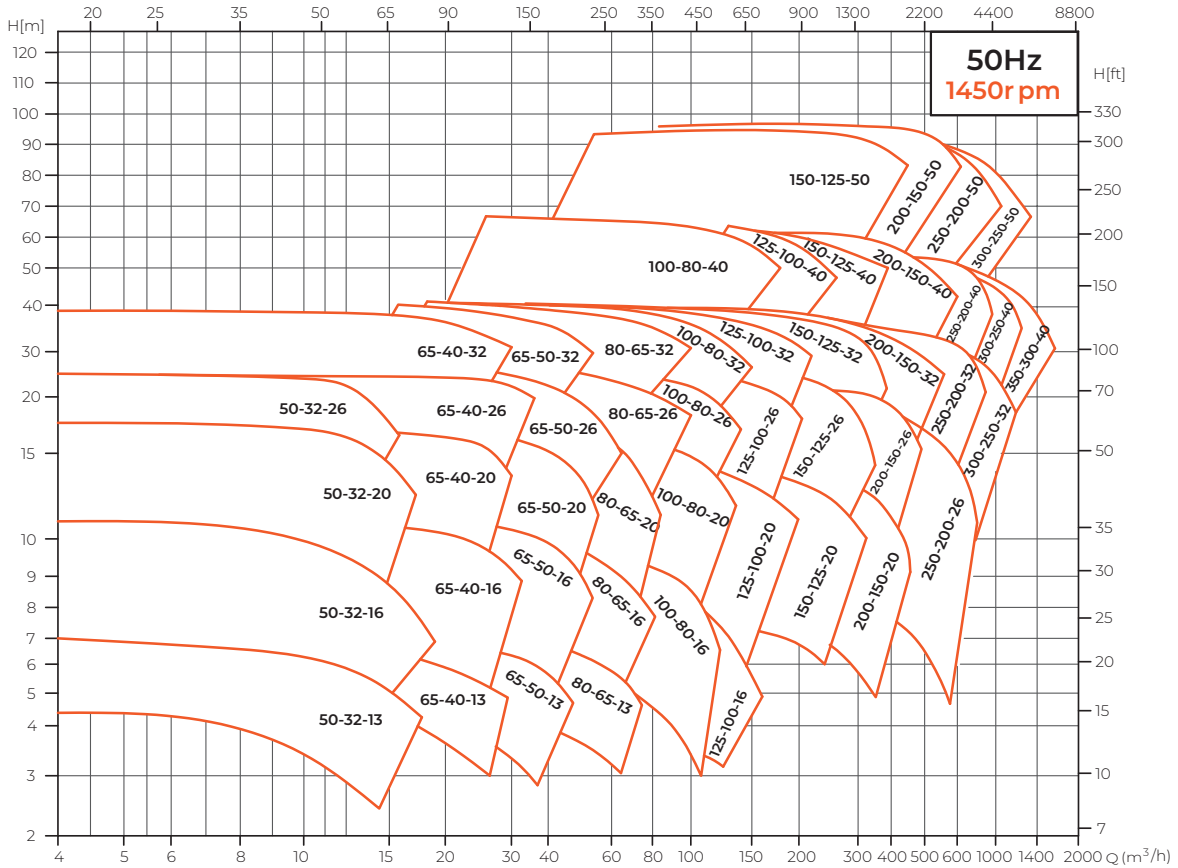

## Dimension

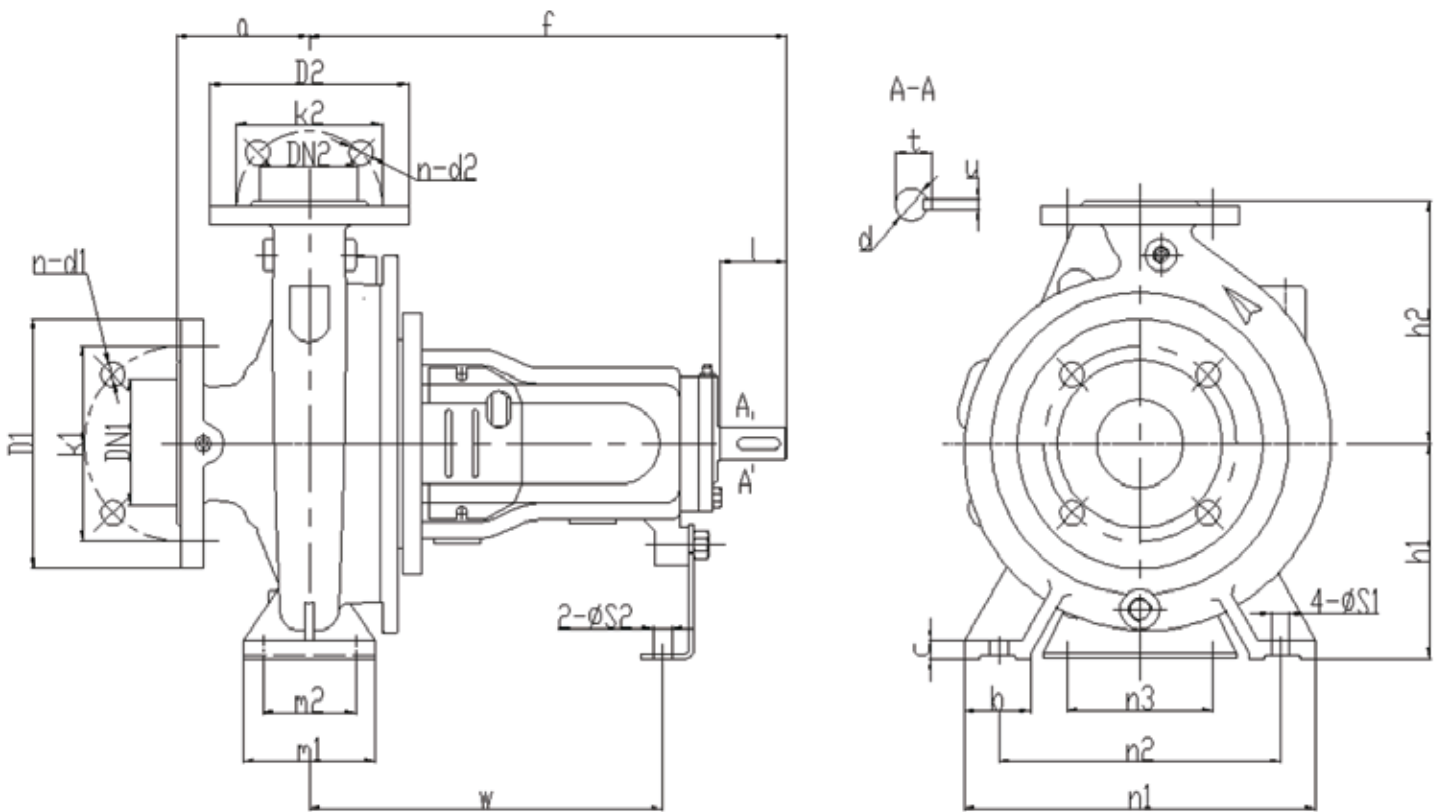

Flange standard (ISO7005.2 DIN2501 PN16 GB/T17241.6 PN1.6)

DN1/DN2	32	40	50	65	80	100	125	150	200	250	300	350	400
D1/D2	140	150	165	185	200	220	250	285	340	405	460	520	580
k1/k2	100	110	125	145	160	180	210	240	295	355	410	470	525
n-d1/n-d2	4- $\Phi$ 18	4- $\Phi$ 18	4- $\Phi$ 18	4- $\Phi$ 18	8- $\Phi$ 18	8- $\Phi$ 18	8- $\Phi$ 18	8- $\Phi$ 22	12- $\Phi$ 22	12- $\Phi$ 26	12- $\Phi$ 26	16- $\Phi$ 26	16- $\Phi$ 30

### Dimension

Model	Bearing inner diameter	Outlet DN2	Inlet DN1	a	f	h1	h2	b	c	n3	m1	m2	n1	n2	S1	S2	w	d	l	t	u		
LEK50-32-13H	25	32	50	80	360	112	140	50	14	100	100	70	190	140	14	14	267	24	50	27	8		
LEK50-32-16H						132	160						240	190									
LEK50-32-20H						160	180						320	250									
LEK50-32-26H						180	225						65	110								125	95
LEL65-40-13H	25	40	65	80	360	200	140	50	14	100	100	70	210	160	14	14	267	24	50	27	8		
LEK65-40-16H						200	160						240	190									
LEK65-40-20H						132	180						265	212									
LEK65-40-26H						160	225						320	250									
LEK65-40-32H	35	65	125	470	180	160	250	65	14	110	125	95	345	280	14	14	342	32	80	35	10		
LEK65-40-32H						180	250						345	280									
LEK65-50-13H	25	50	100	360	160	225	160	50	18	100	100	70	240	190	14	14	267	24	50	27	8		
LEK65-50-16H						160	180						265	212									
LEK65-50-20H						160	200						320	250									
LEK65-50-26H						180	225						320	250									
LEK65-50-32H						125	200						280	345								280	
LEK80-65-13H	25	65	80	100	360	225	180	65	14	110	125	95	280	212	14	14	267	24	50	27	8		
LEK80-65-16H						180	200						320	250									
LEK80-65-20H						180	225						320	250									
LEK80-65-26H						200	250						360	280									
LEK80-65-32H						470	250						280	400								315	
LEK100-80-16H	25	80	100	125	470	361	280	225	14	110	125	95	320	250	14	14	268	24	50	27	8		
LEK100-80-20H	200					250	345	280															
LEK100-80-26H	200					280	400	315															
LEK100-80-32H	225					315	80	16	160				120	400								315	18
LEK100-80-40H	530					250	355	83	18				440	340								370	

Model	Bearing inner diameter	Outlet DN2	Inlet DN1	a	f	h1	h2	b	c	n3	m1	m2	n1	n2	S1	S2	w	d	l	t	u															
LEK125-100-16H	35	100	125	125	470	280	250	80	15	110	160	120	360	280	18	342	32	80	35	10																
LEK125-100-20H						250	280	80	16																											
LEK125-100-26H						250	280																													
LEK125-100-32H						280	315																													
LEK125-100-40H	45	125	150	140	530	315	355	100	20	200	150	500	400	23	370																					
LEK150-125-20H	35					470	355	315	80	16	160	120	400	315	18	342	32	80	3	10																
LEK150-125-26H							280	355																												
LEK150-125-32H	45					530	250	355	18	110	500	400	14	370	42	110	45	12																		
LEK150-125-40H		280	400																																	
LEK150-125-50H	55	150	200	160	530	670	315	450	25	23	550	450	23	504	48	110	51	14																		
LEK200-150-20H	35					500	315	400	100										18	200	150	550	450	371	32	80	35	10								
LEK200-150-26H							45	530																					315	400	550	450	30	42	45	12
LEK200-150-32H																													335	450						
LEK200-150-40H	55	670	425	500	22	504	48	110	51	14																										
LEK200-150-50H			670	425							500																									
LEK250-200-26H	45	200	250	180	548	355	450	120	20	110	220	170	600	480	28	388	42	45	12																	
LEK250-200-32H	55					670	400													480	220	170	600	480	505	48	51	14								
LEK250-200-40H							450													480									250							
LEK250-200-50H	65					200	T20													425	560	100	22	140	200	150	660	560	23	19	515	60	140	64	18	
LEK300-250-32H	55	250	300	220	691	355	520	150	26	110	250	200	660	510	28	14	525	48	110	51	14															
LEK300-250-40H					682	400	560										516																			
LEK300-250-50H	65	300	350	250	720	450	670	120	32	140	240	190	750	650	23	19	515	60	140	64	18															
LEK350-300-40H	65										300	720	425	120	30	250	190	760	660	30	19	515	60	140	64	18										

### END SUCTION PUMP PERFORMANCE CURVE LEK SERIES

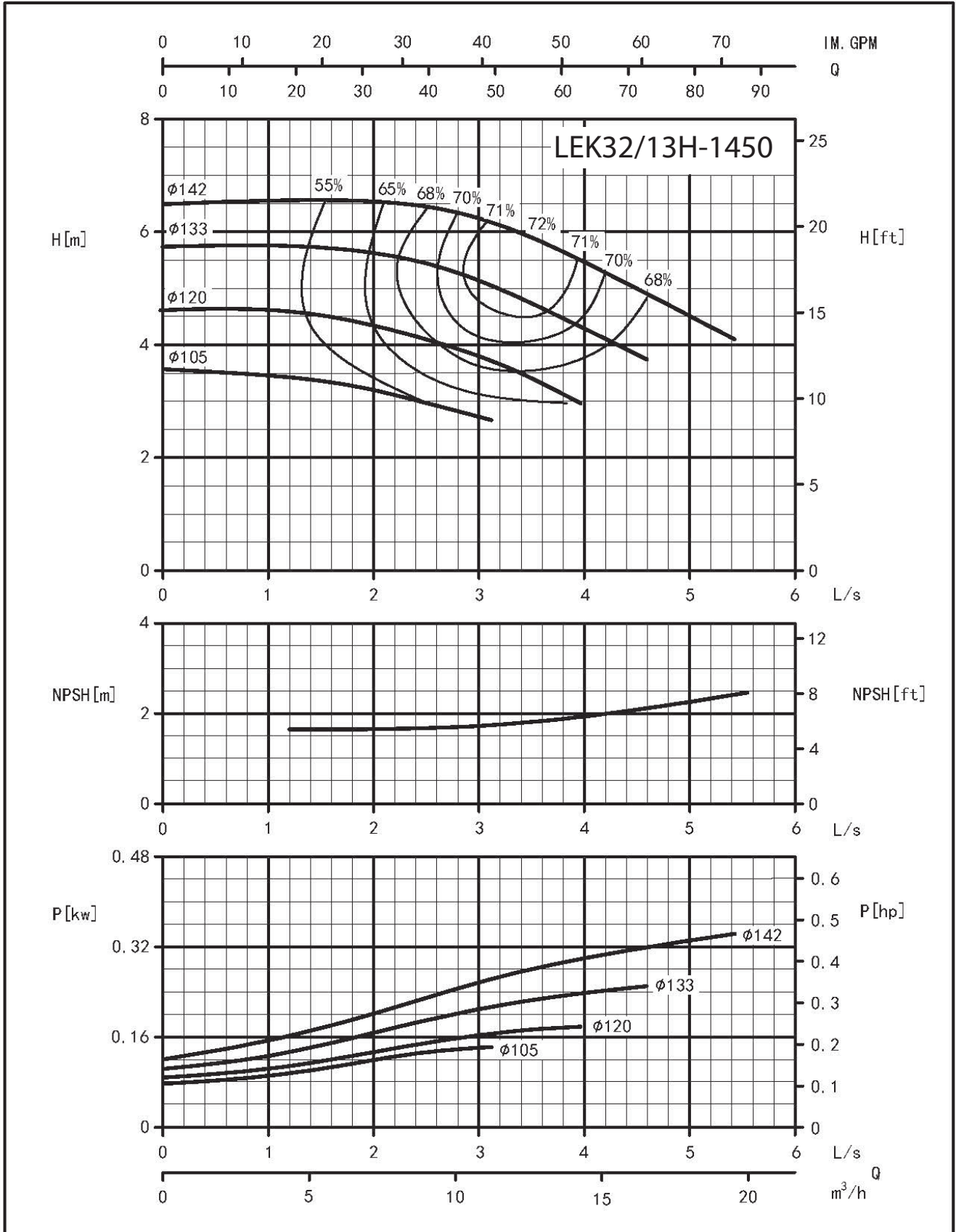

## END SUCTION PUMP PERFORMANCE CURVE LEK SERIES

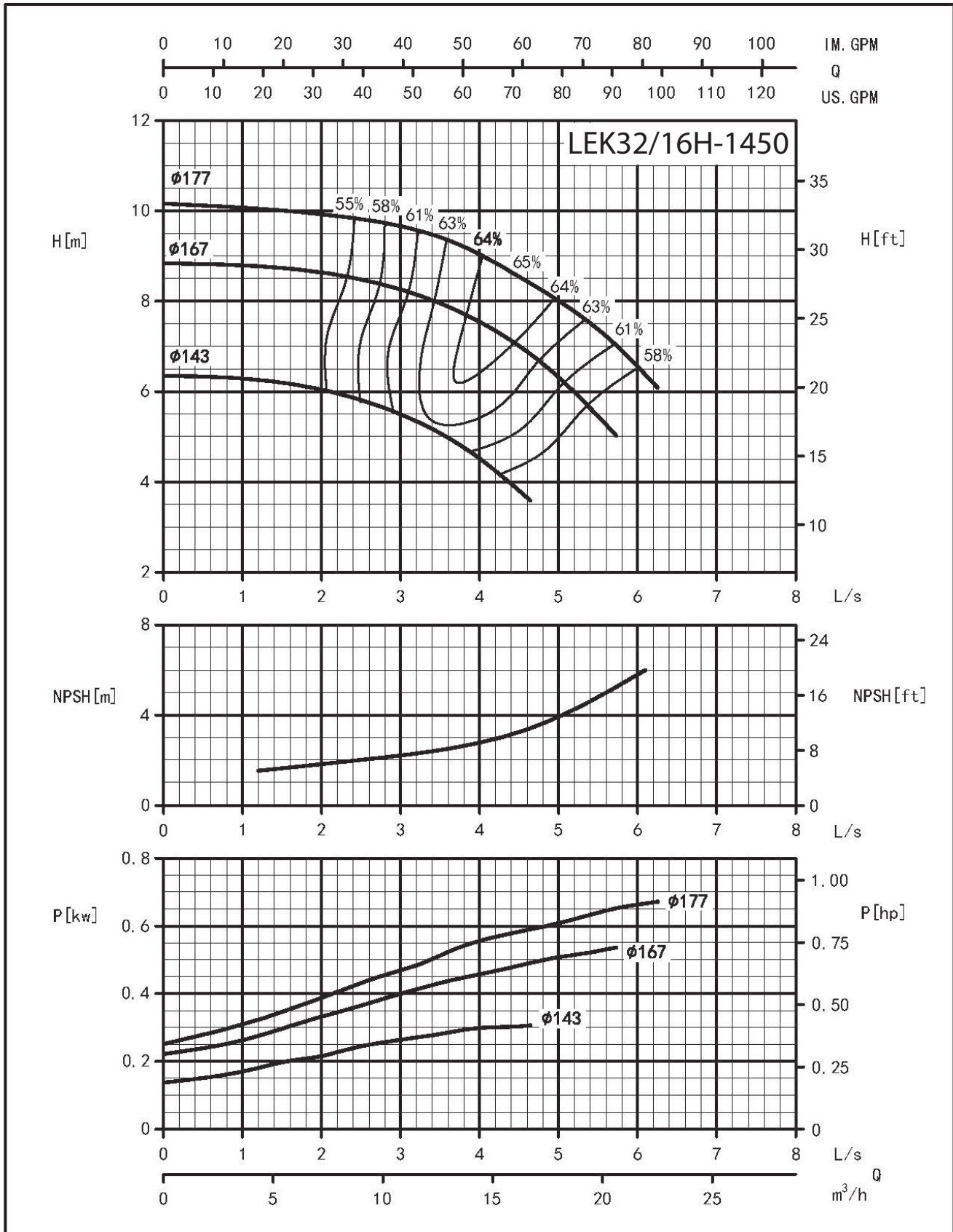

### END SUCTION PUMP PERFORMANCE CURVE LEK SERIES

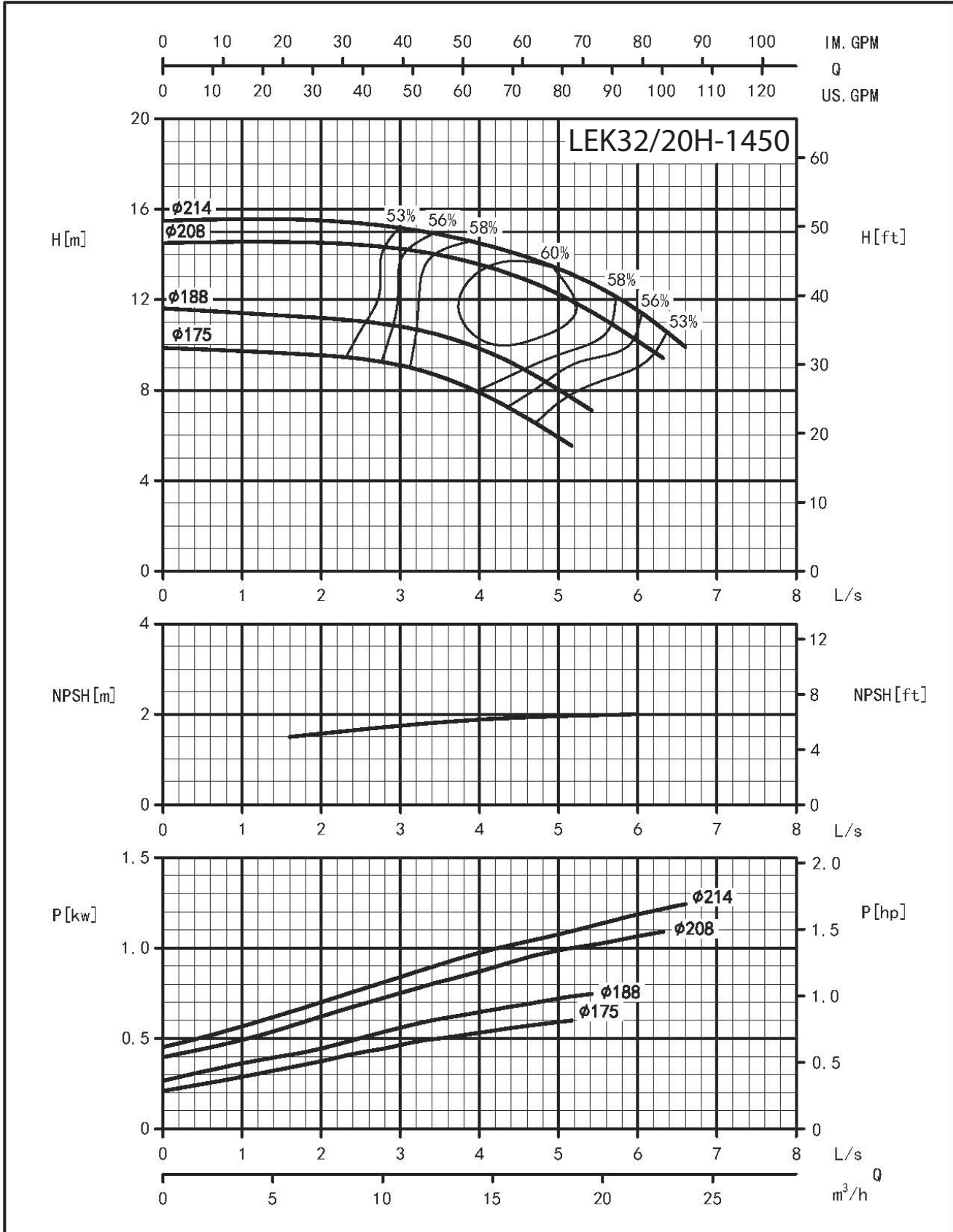

## END SUCTION PUMP PERFORMANCE CURVE LEK SERIES

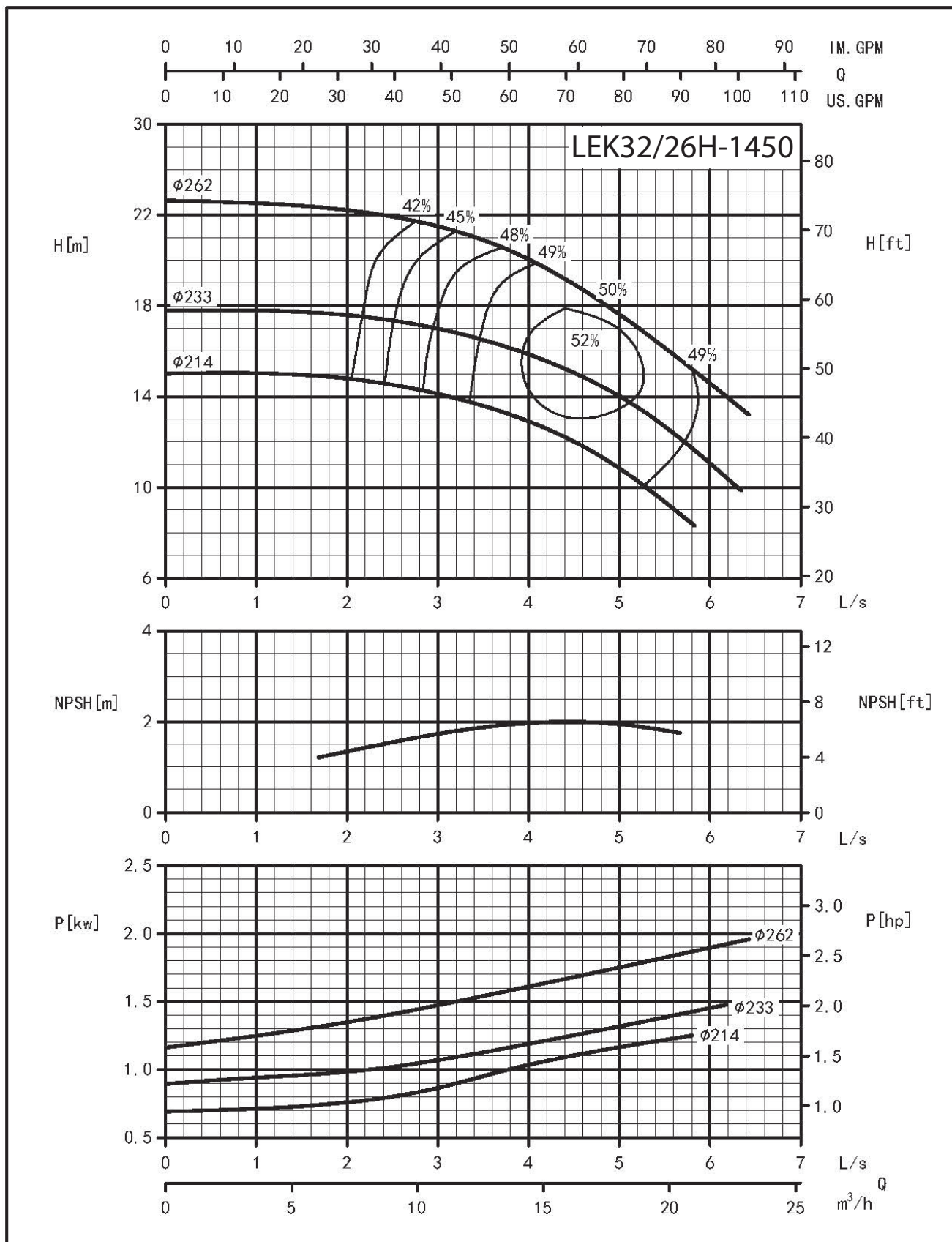

### END SUCTION PUMP PERFORMANCE CURVE LEK SERIES

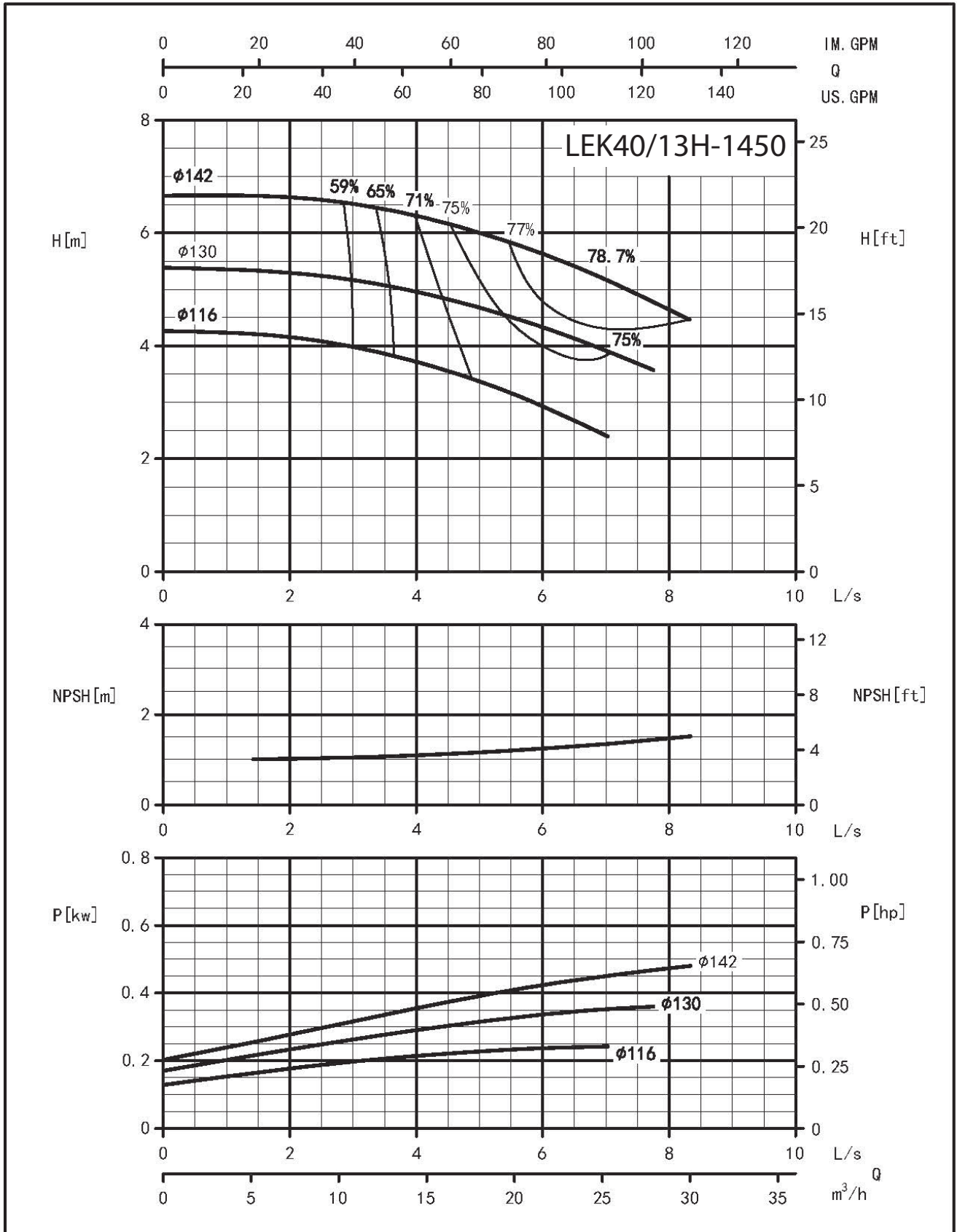

## END SUCTION PUMP PERFORMANCE CURVE LEK SERIES

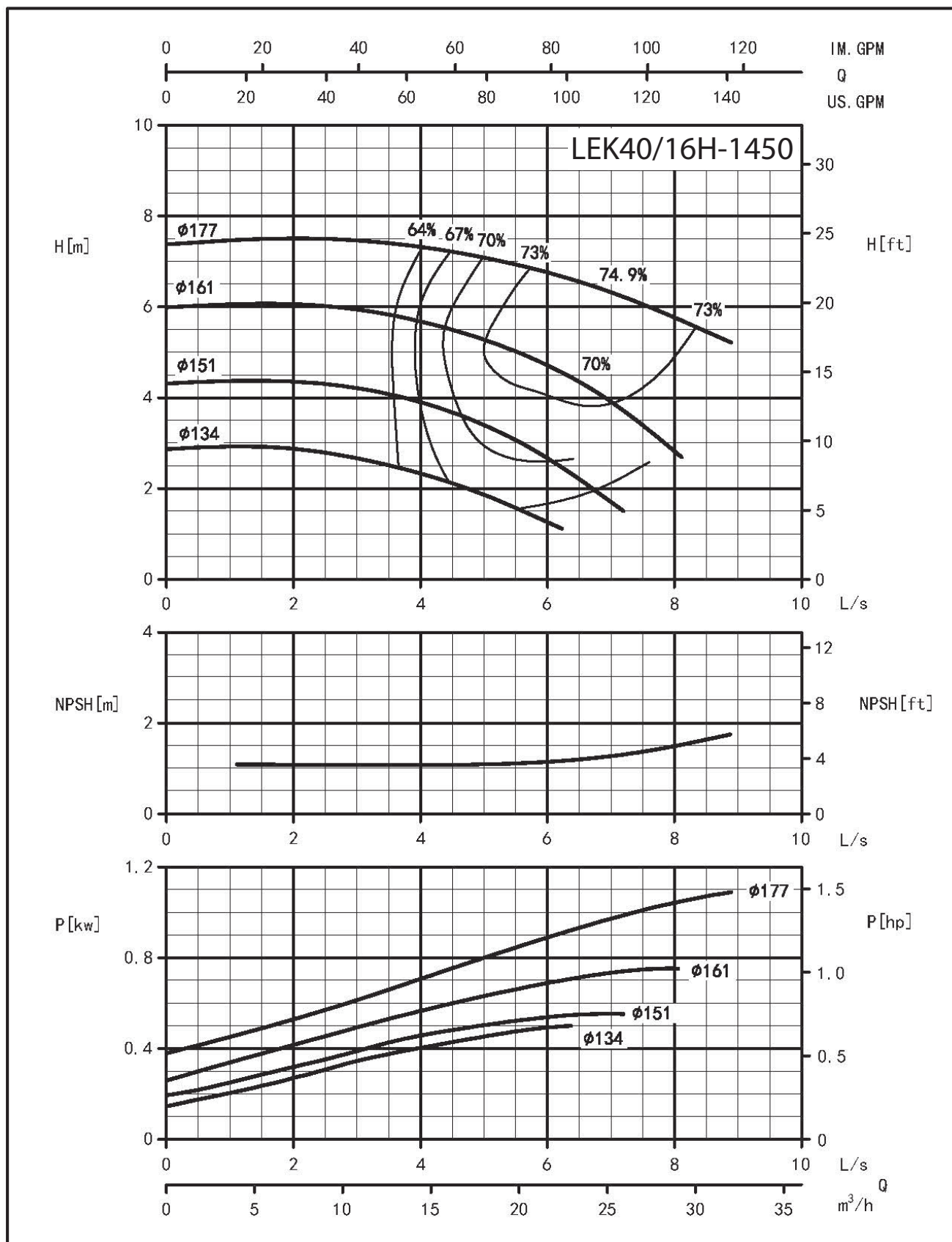

### END SUCTION PUMP PERFORMANCE CURVE LEK SERIES

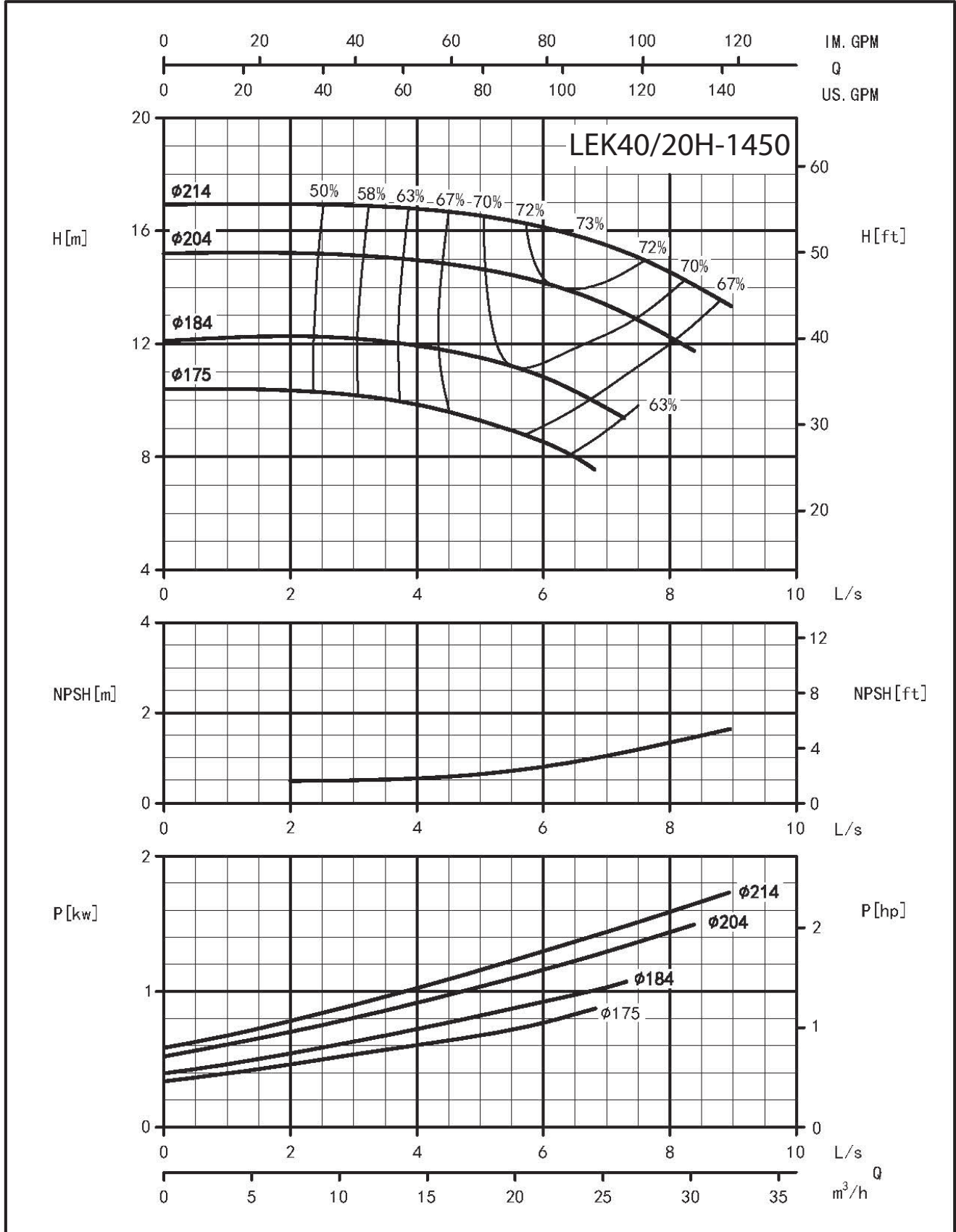

## END SUCTION PUMP PERFORMANCE CURVE LEK SERIES

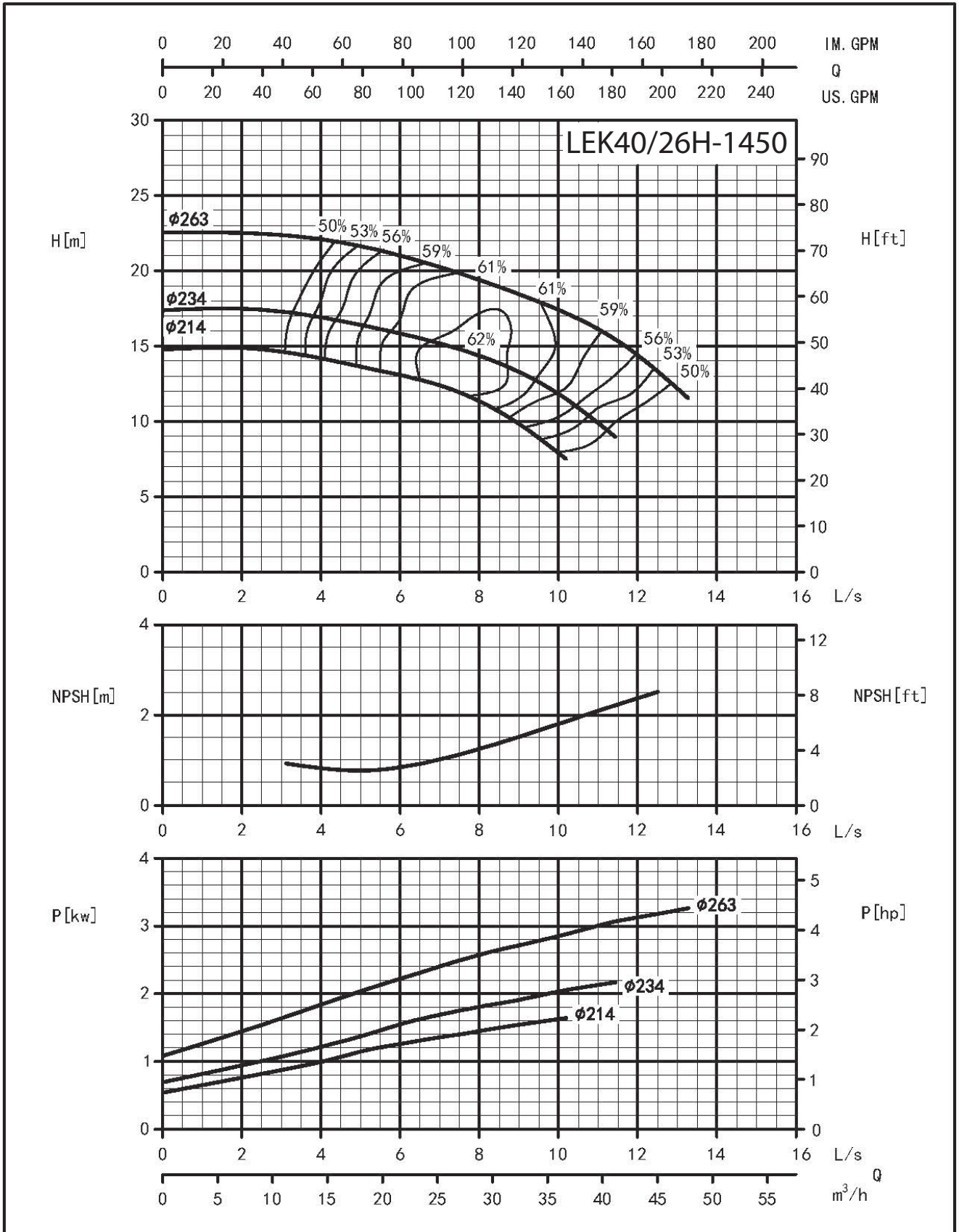

### END SUCTION PUMP PERFORMANCE CURVE LEK SERIES

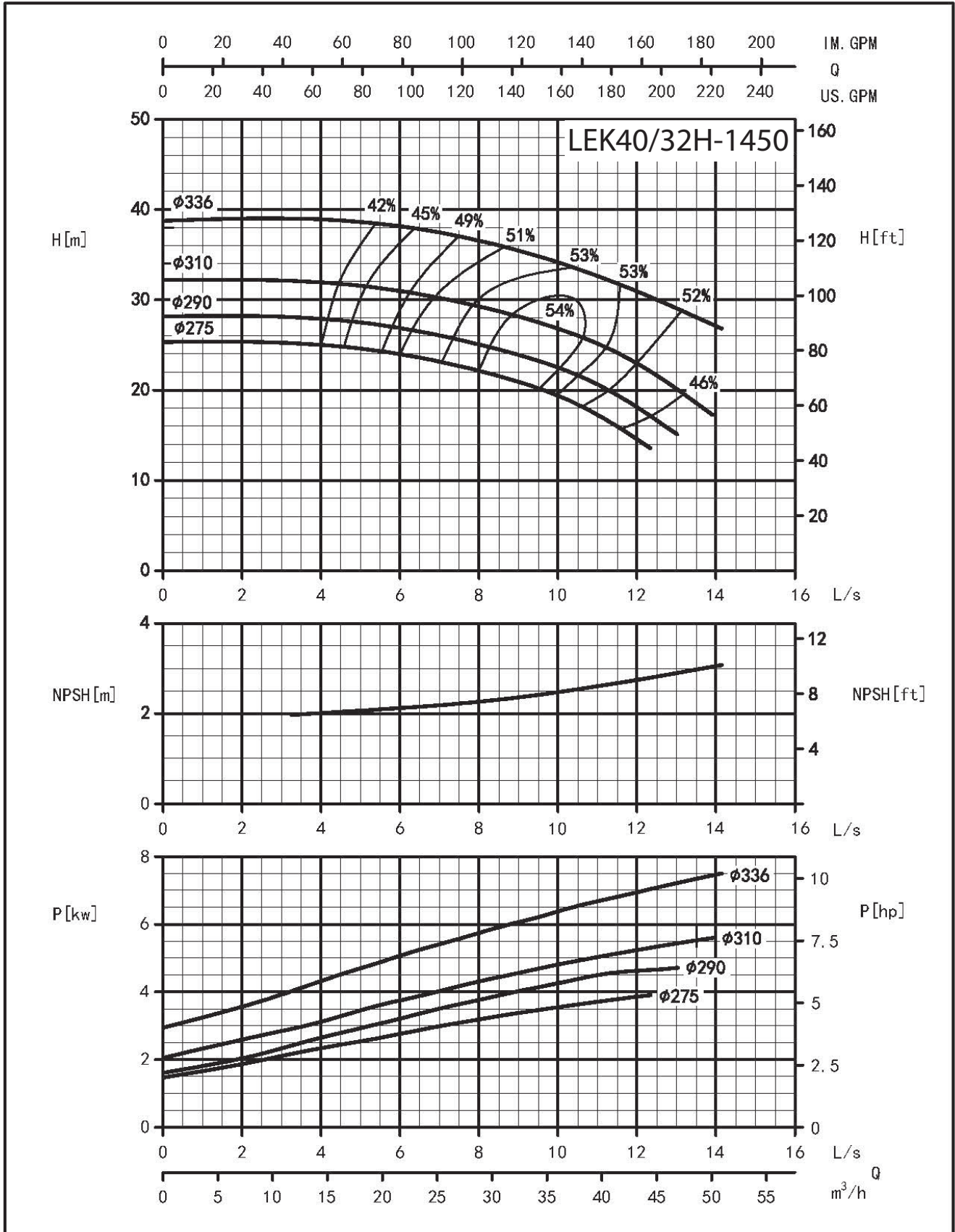

## END SUCTION PUMP PERFORMANCE CURVE LEK SERIES

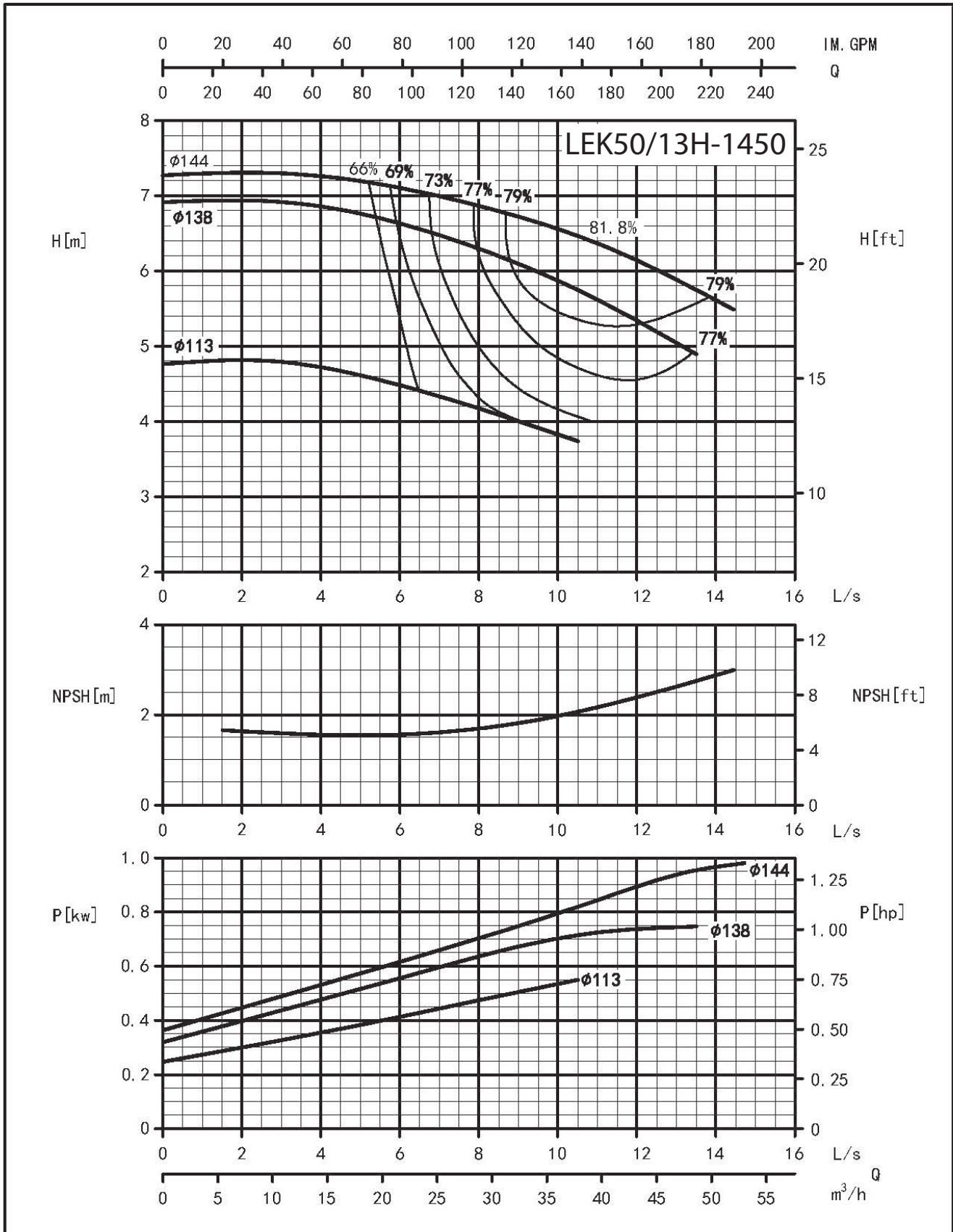

### END SUCTION PUMP PERFORMANCE CURVE LEK SERIES

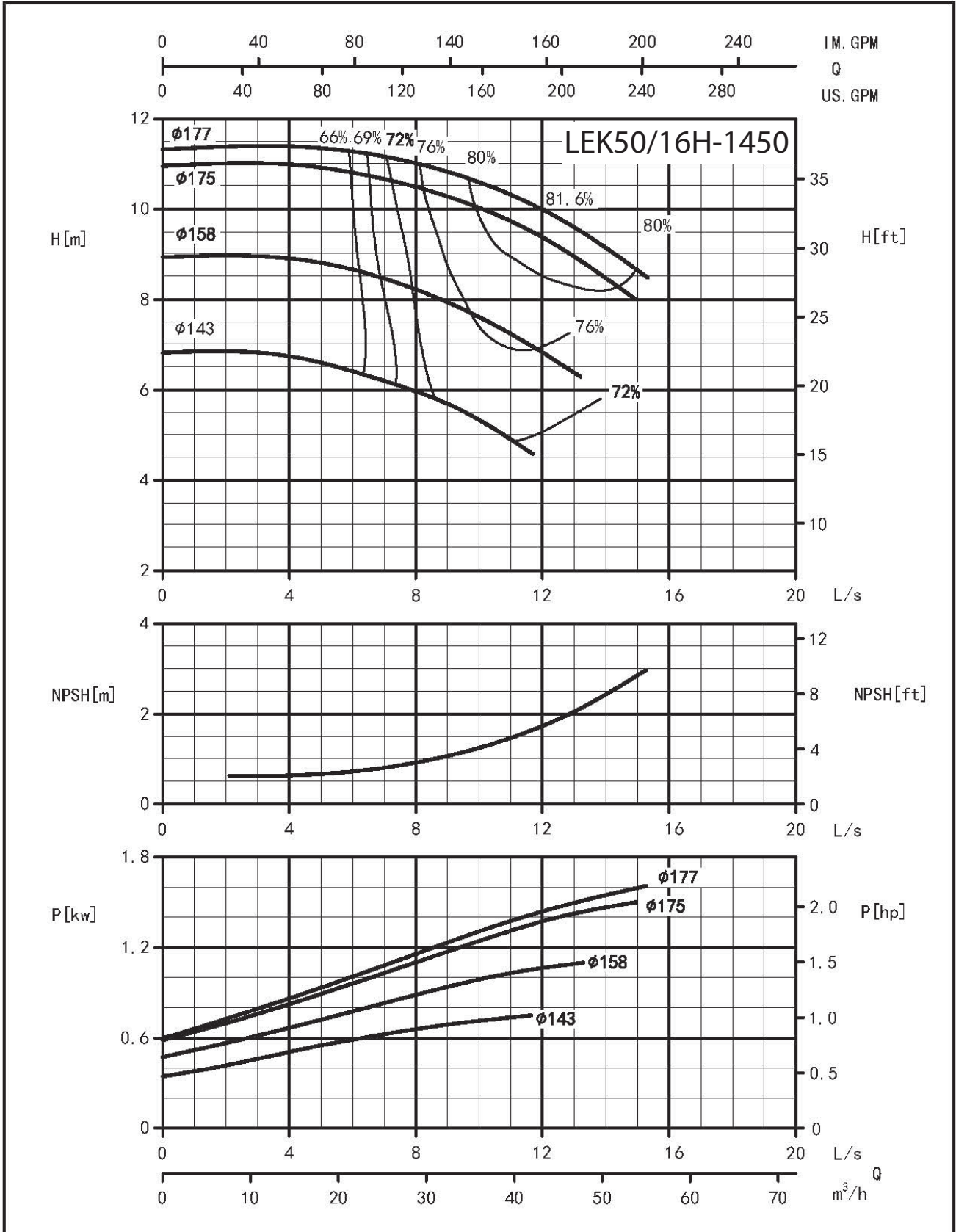

## END SUCTION PUMP PERFORMANCE CURVE LEK SERIES

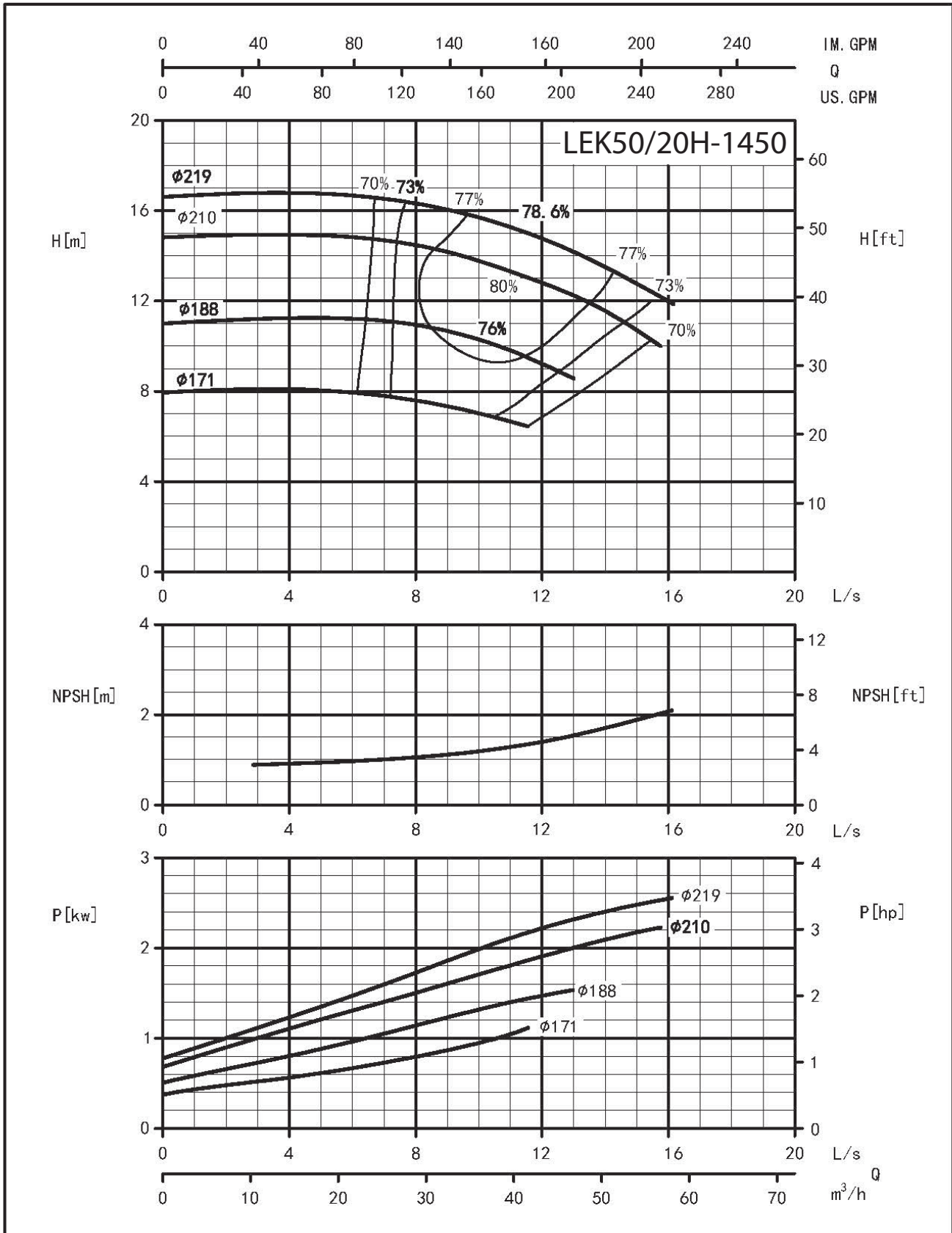

### END SUCTION PUMP PERFORMANCE CURVE LEK SERIES

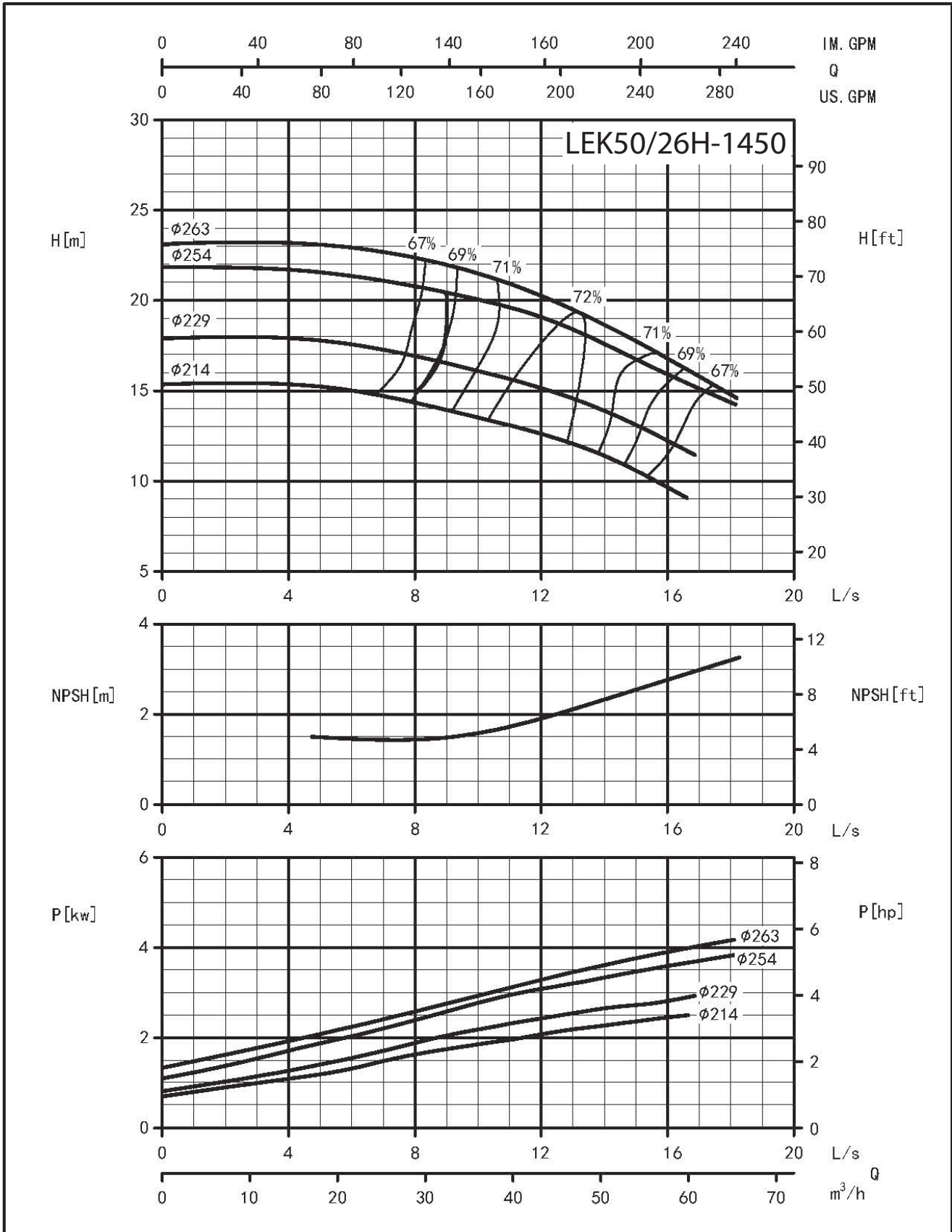

## END SUCTION PUMP PERFORMANCE CURVE LEK SERIES

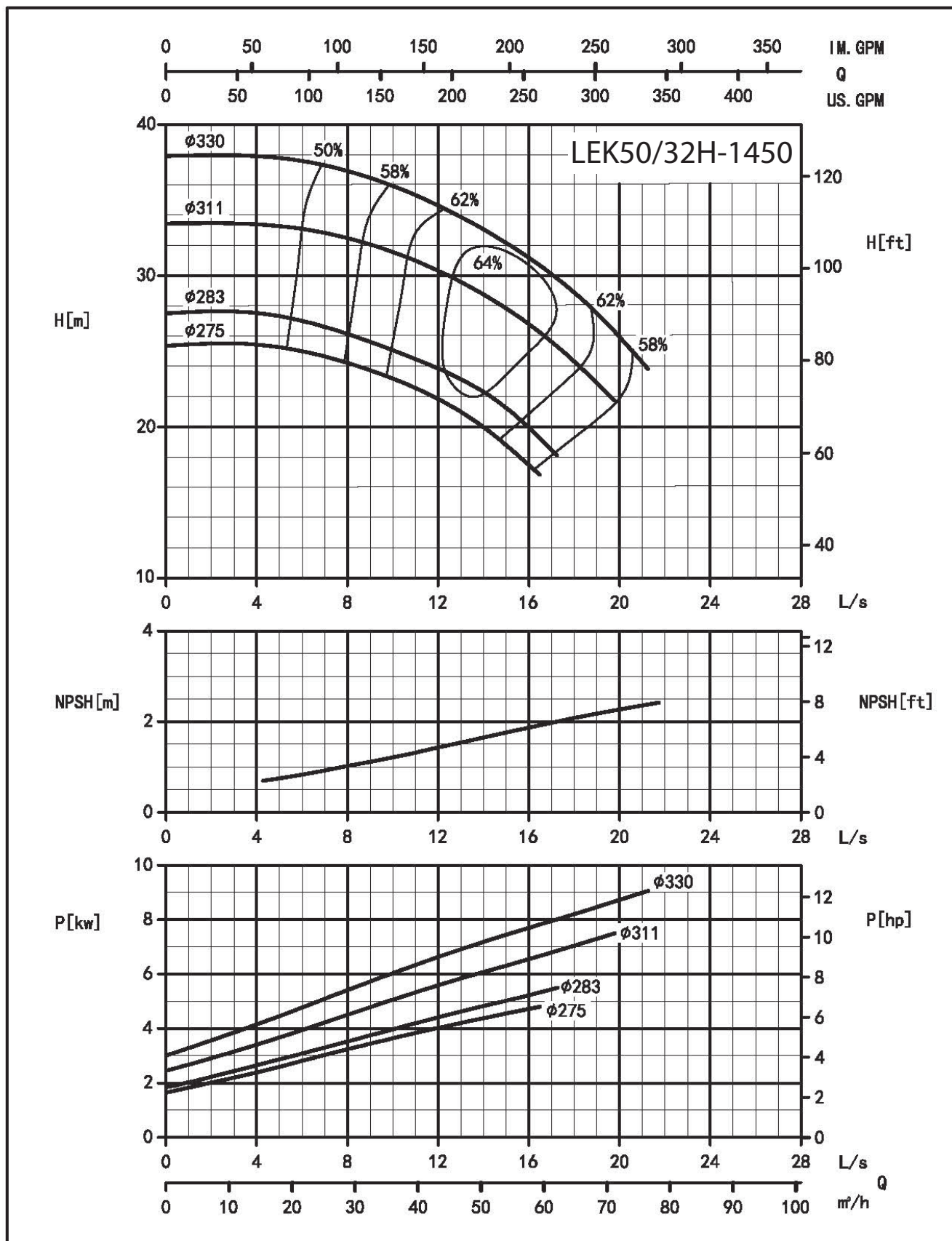

### END SUCTION PUMP PERFORMANCE CURVE LEK SERIES

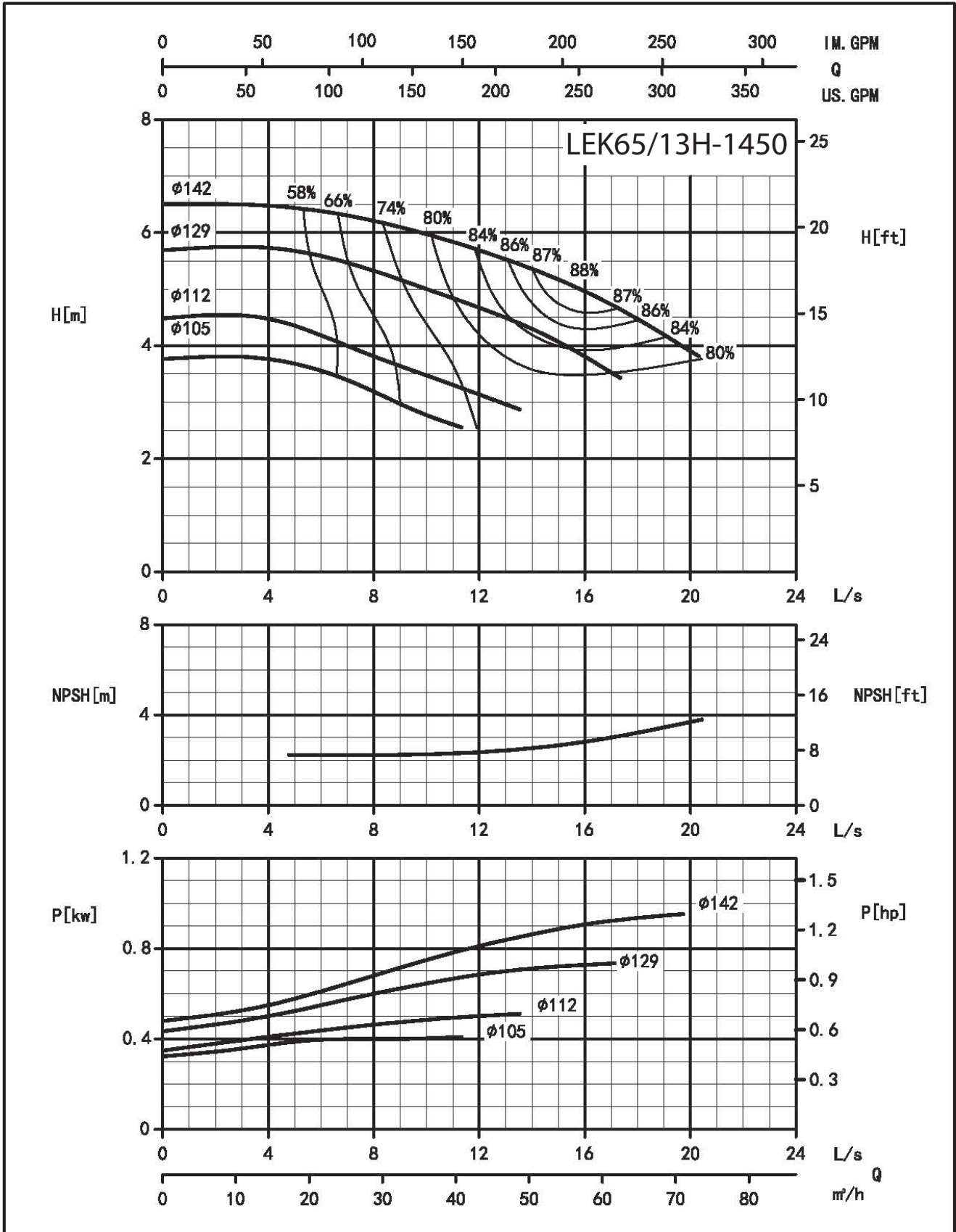

## END SUCTION PUMP PERFORMANCE CURVE LEK SERIES

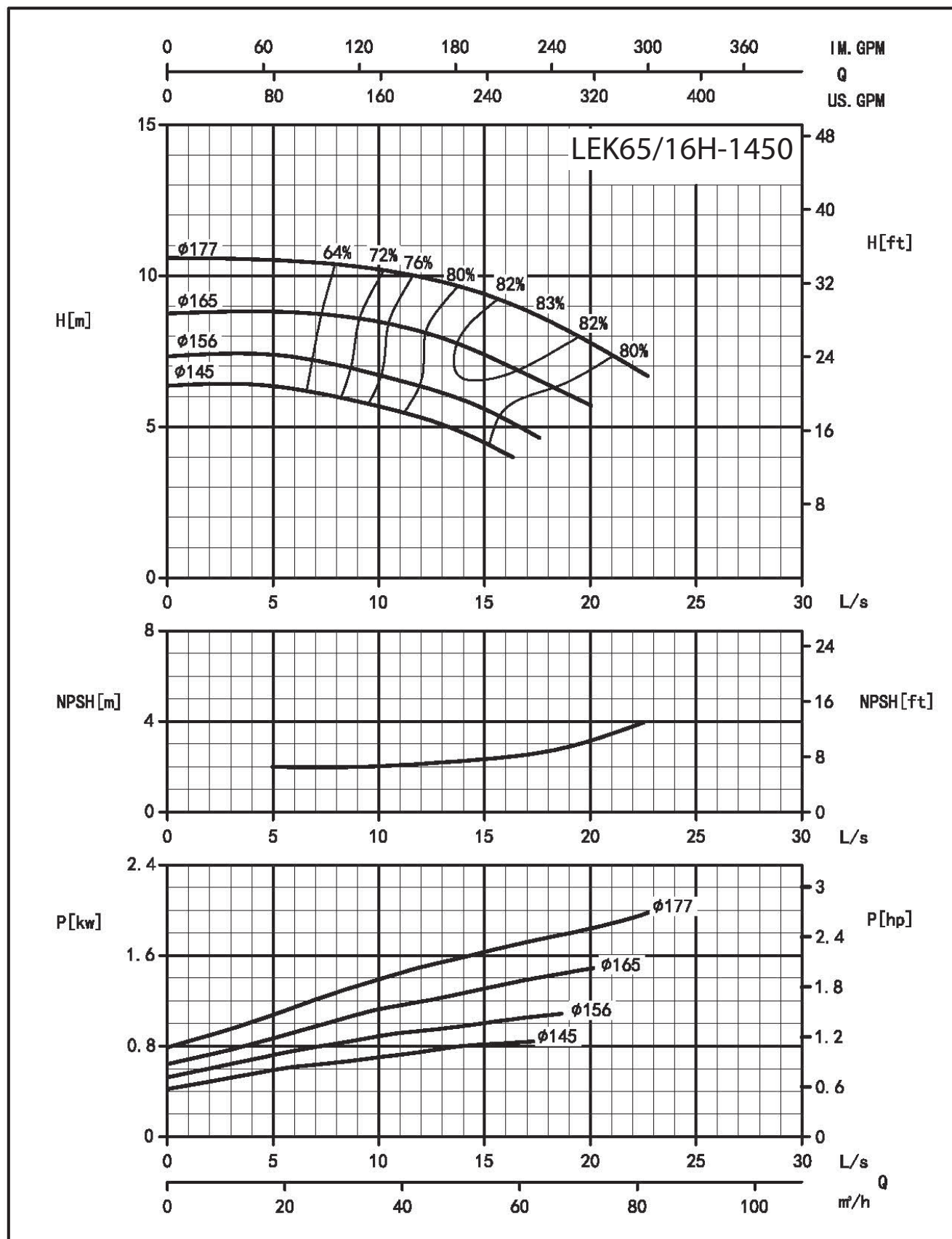

### END SUCTION PUMP PERFORMANCE CURVE LEK SERIES

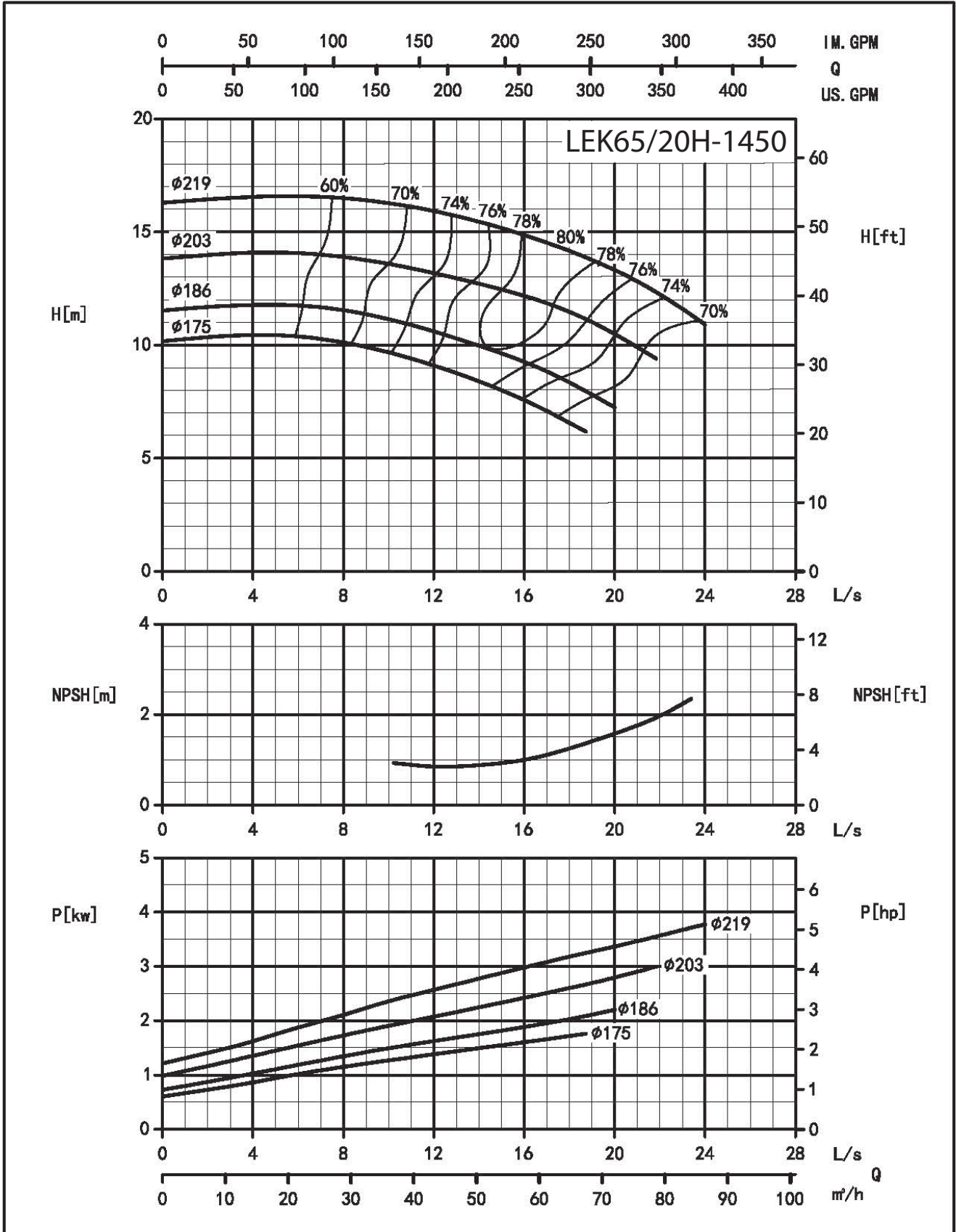

## END SUCTION PUMP PERFORMANCE CURVE LEK SERIES

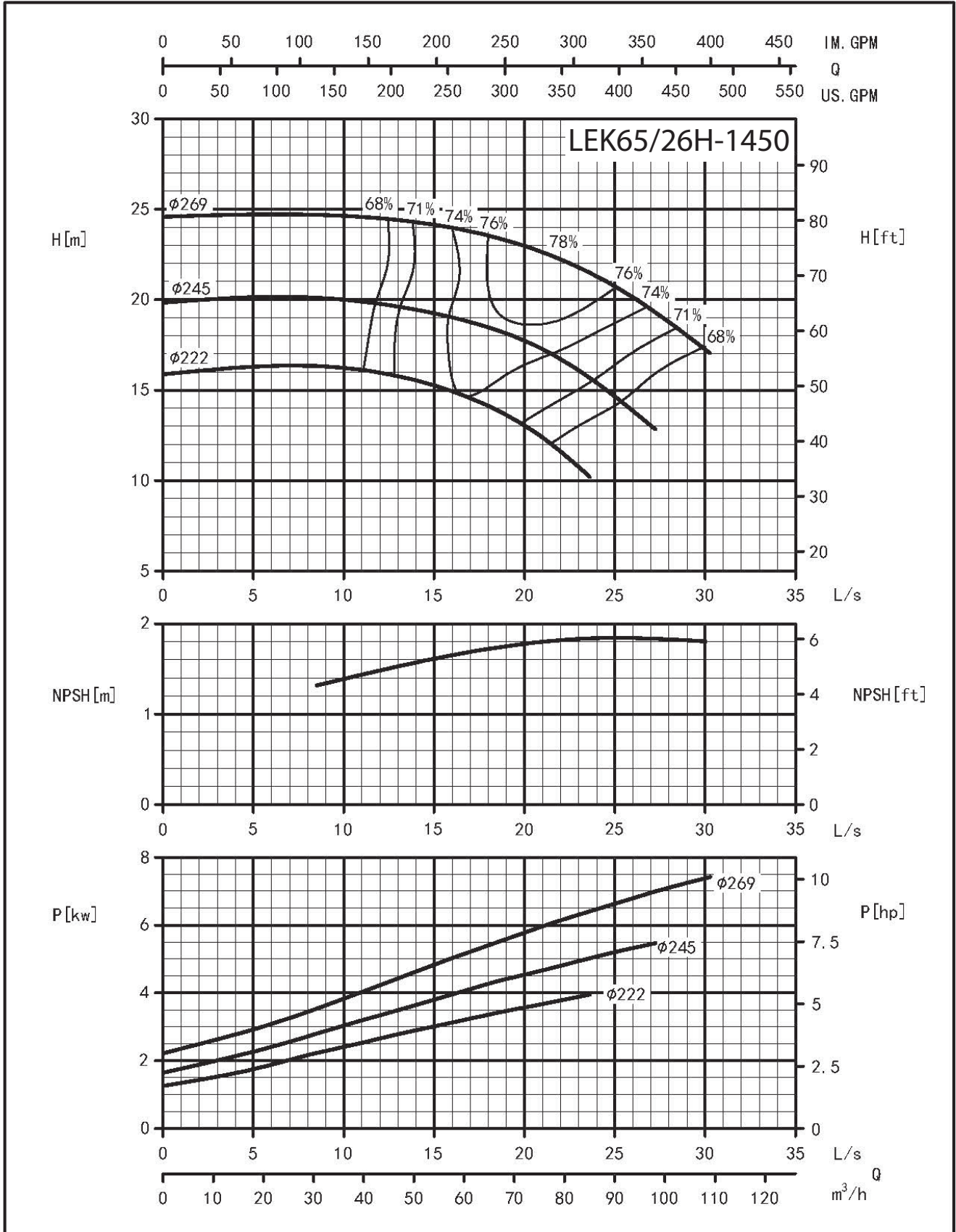

### END SUCTION PUMP PERFORMANCE CURVE LEK SERIES

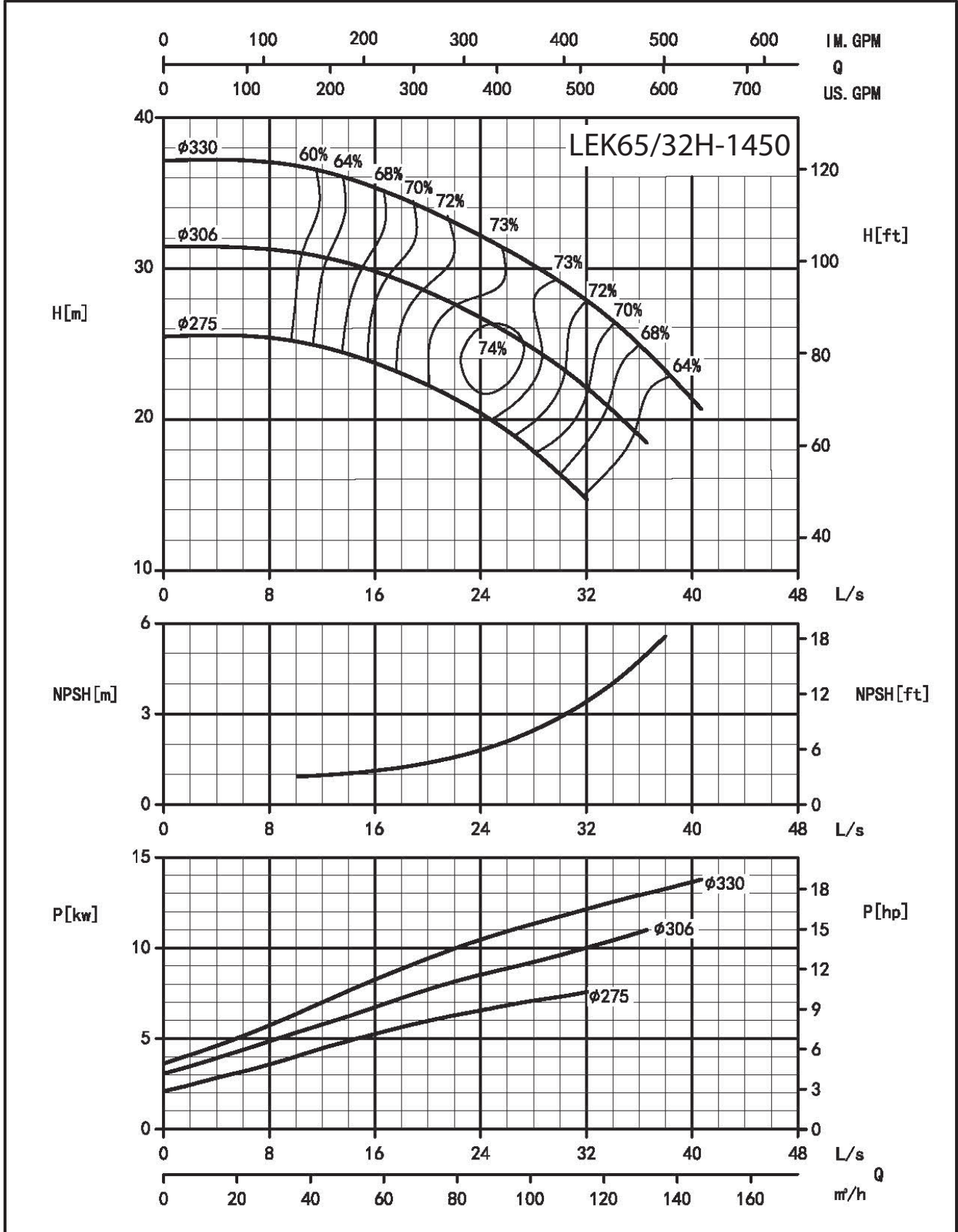

## END SUCTION PUMP PERFORMANCE CURVE LEK SERIES

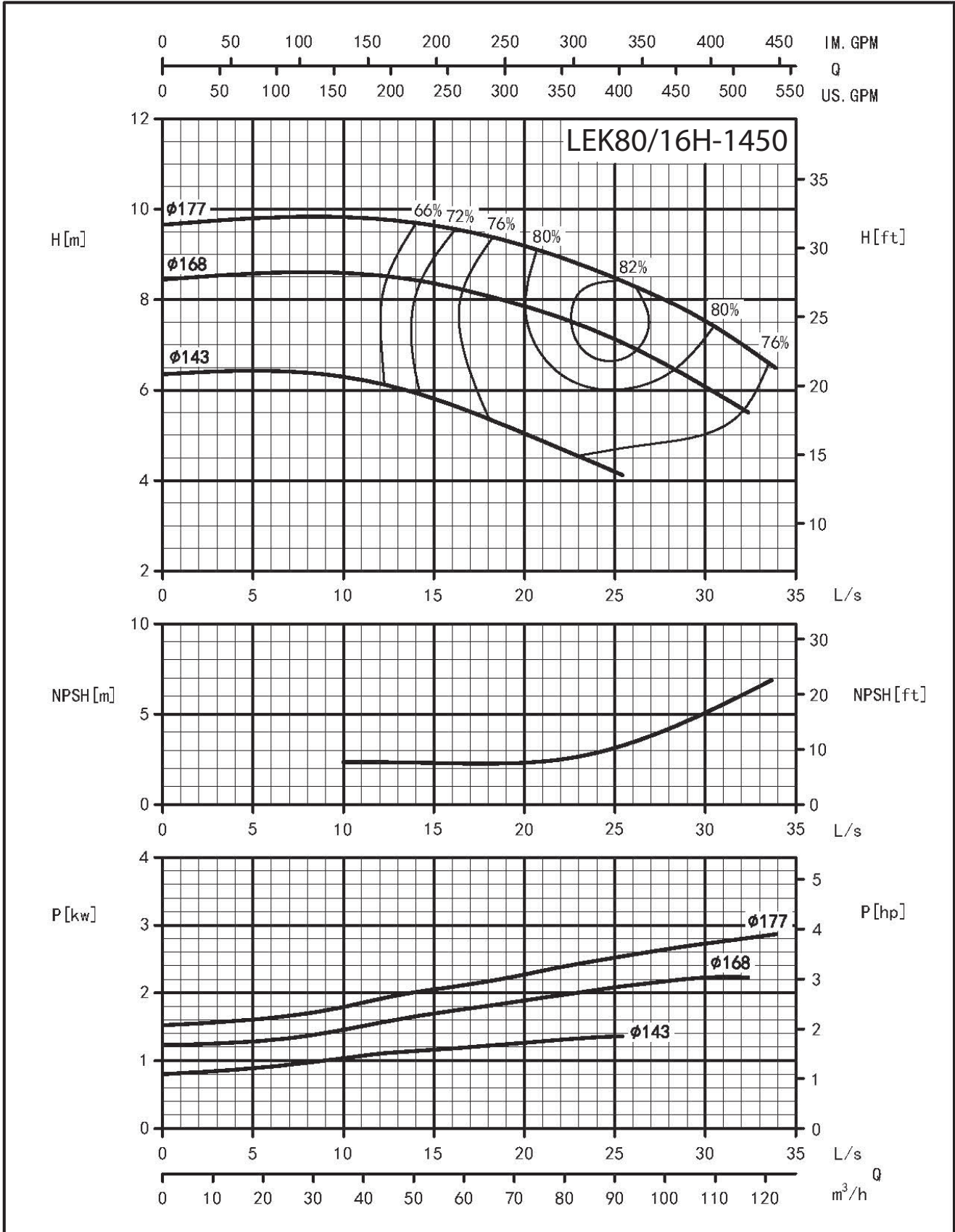

### END SUCTION PUMP PERFORMANCE CURVE LEK SERIES

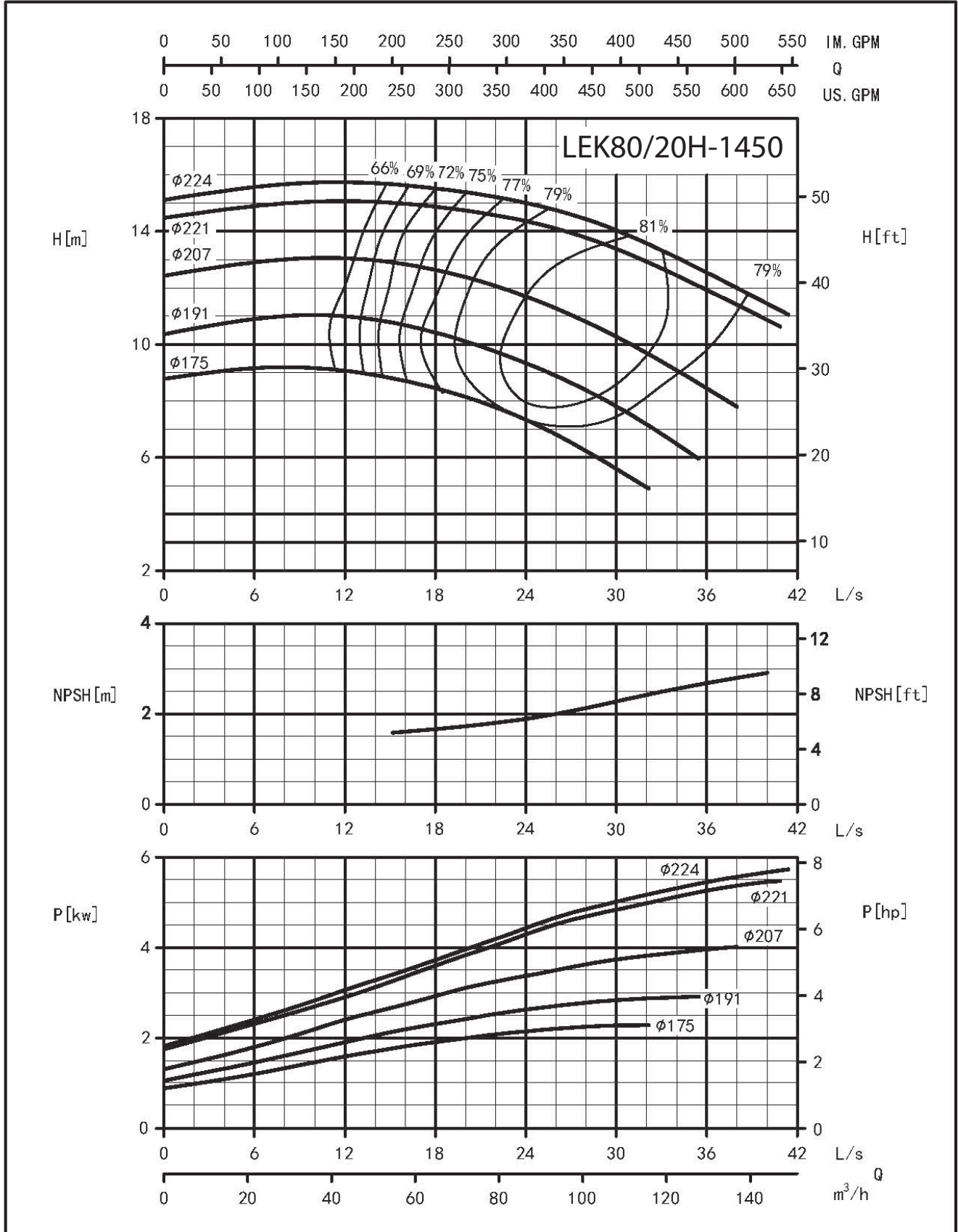

## END SUCTION PUMP PERFORMANCE CURVE LEK SERIES

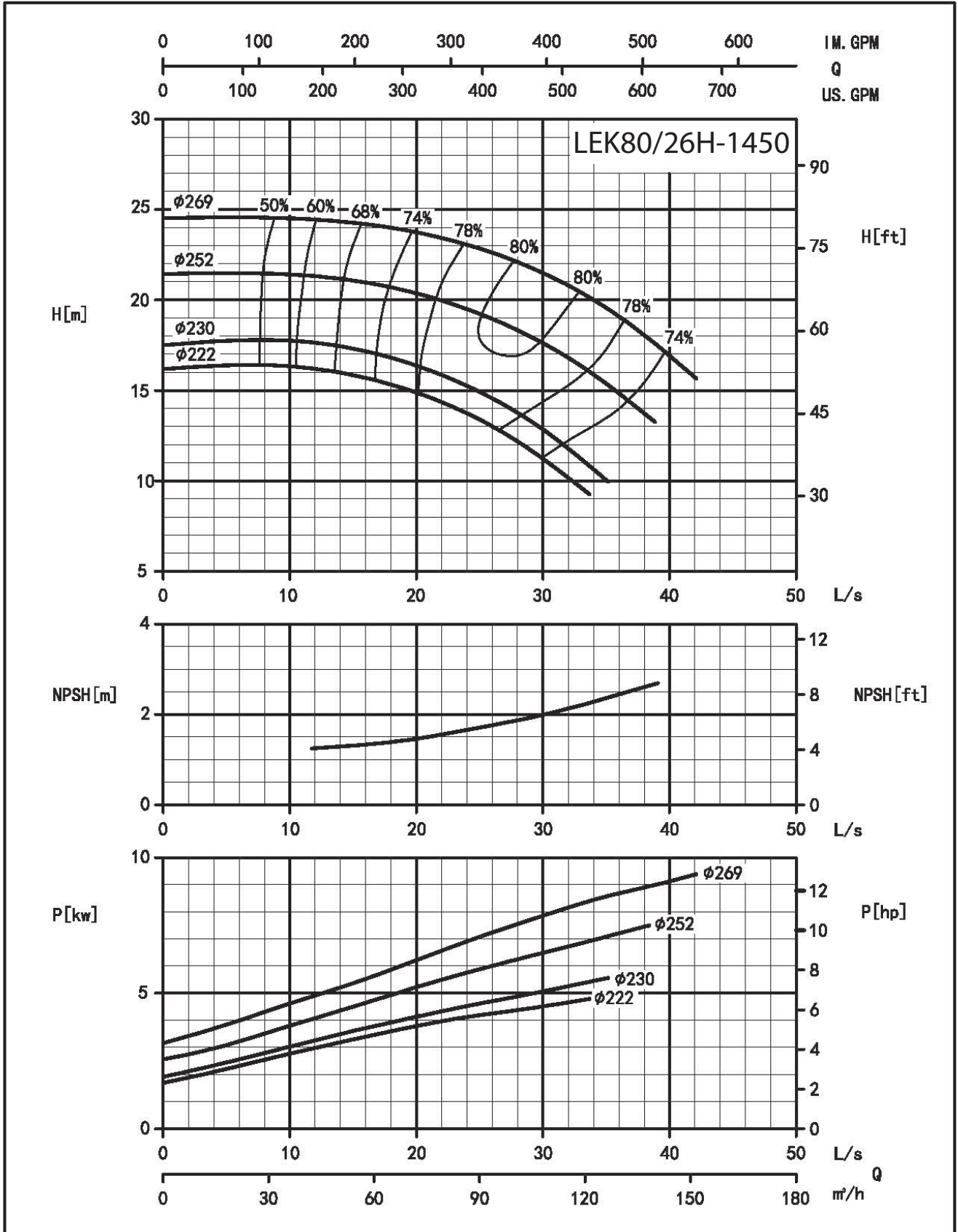

### END SUCTION PUMP PERFORMANCE CURVE LEK SERIES

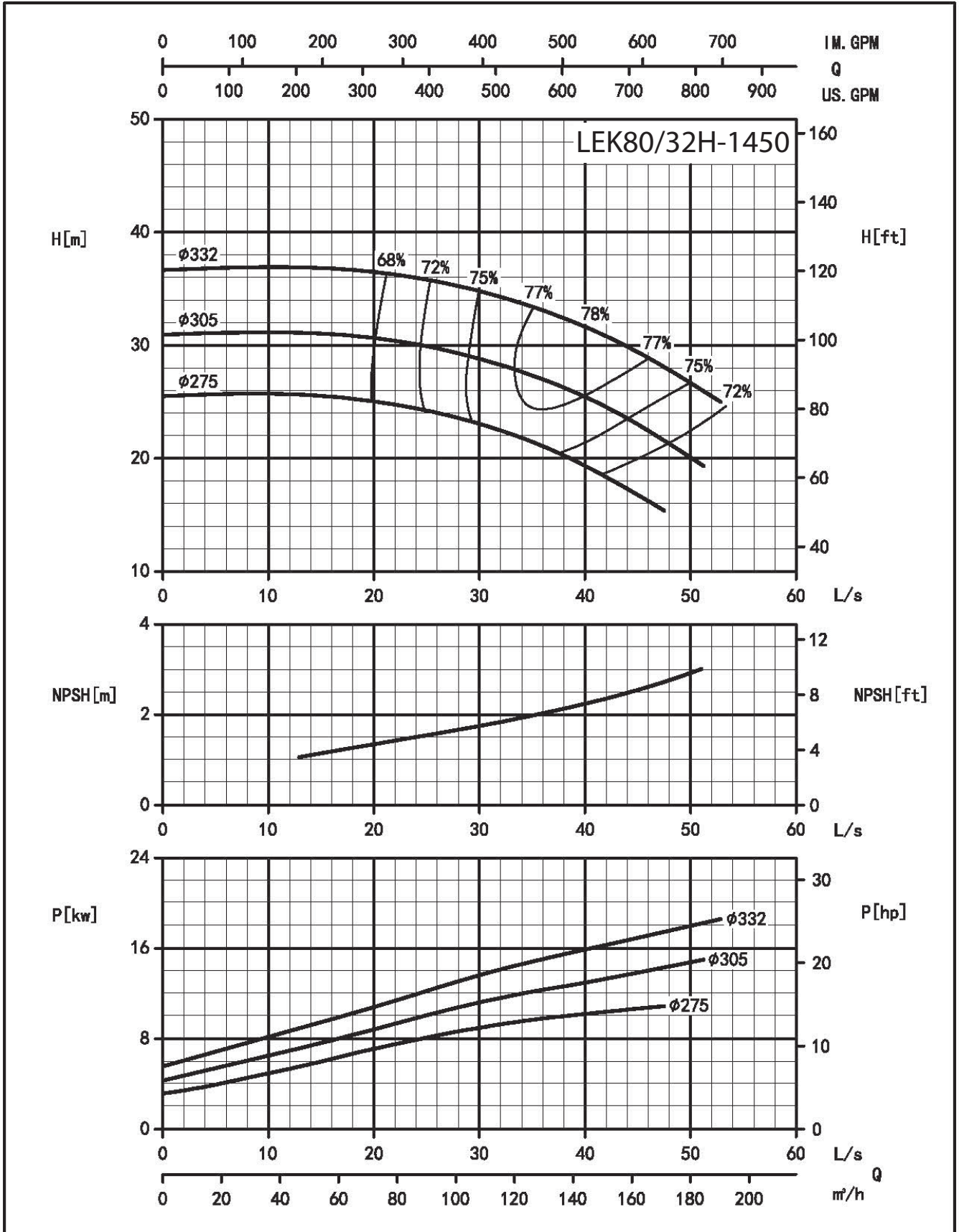

**END SUCTION PUMP PERFORMANCE CURVE  
LEK SERIES**

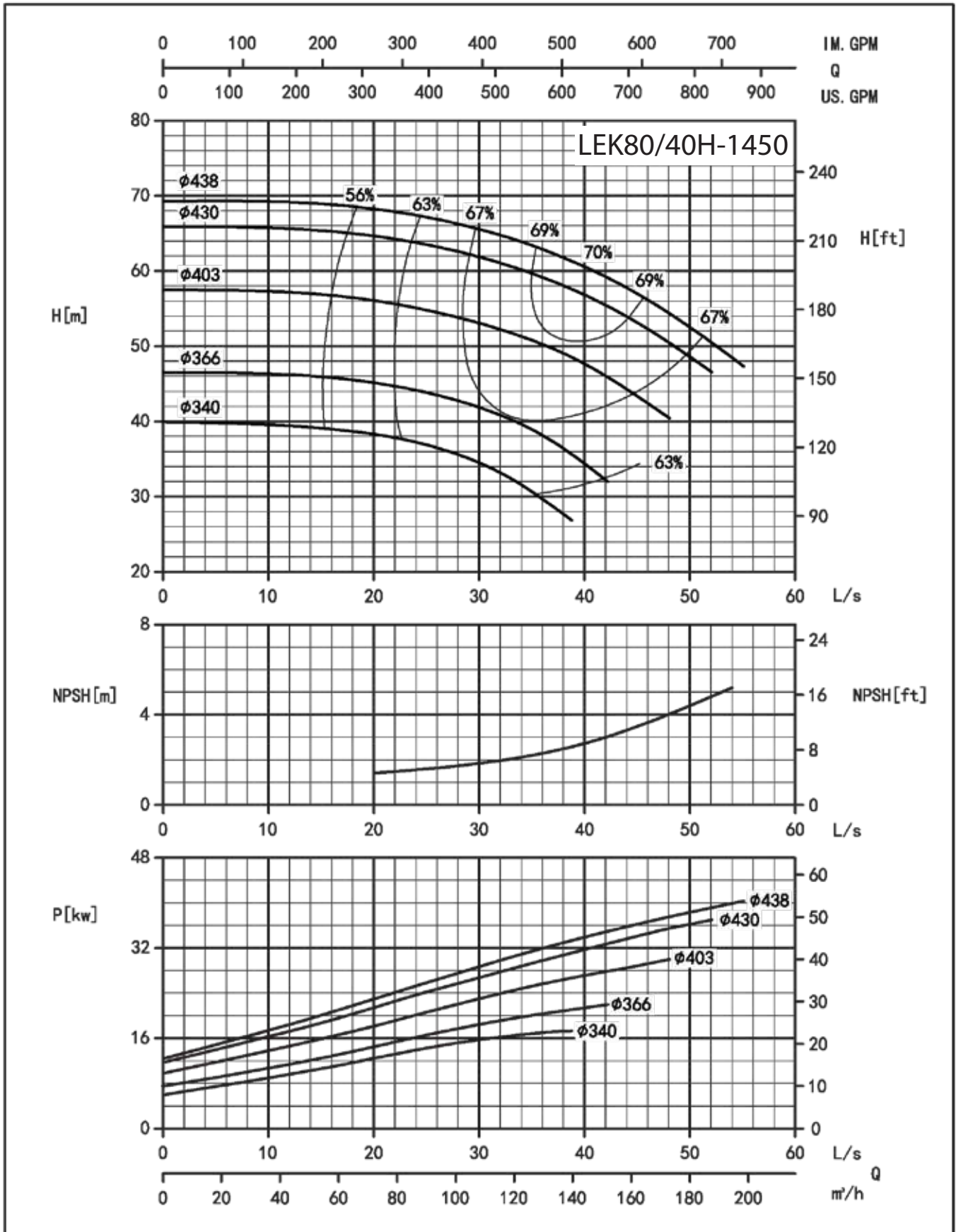

### END SUCTION PUMP PERFORMANCE CURVE LEK SERIES

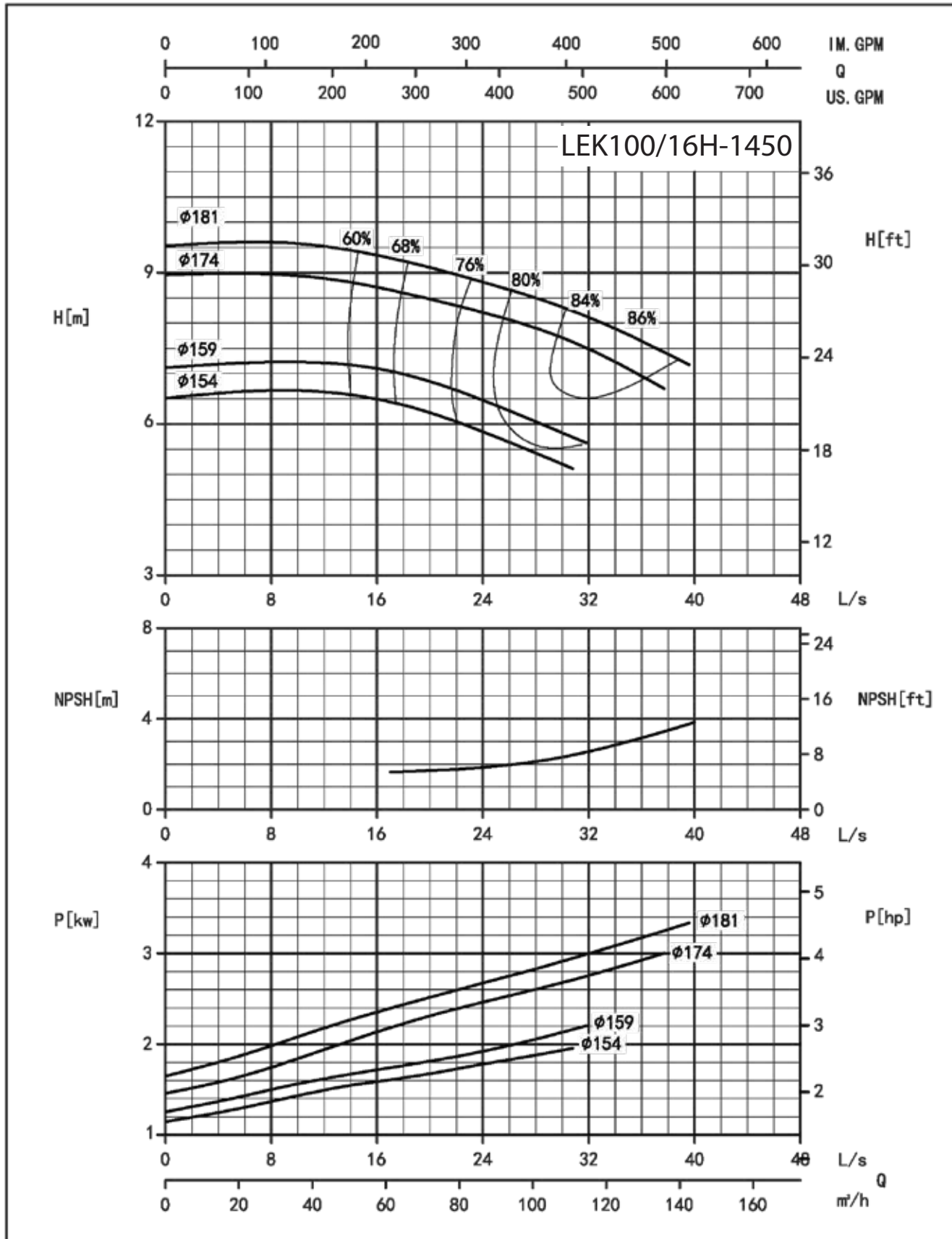

## END SUCTION PUMP PERFORMANCE CURVE LEK SERIES

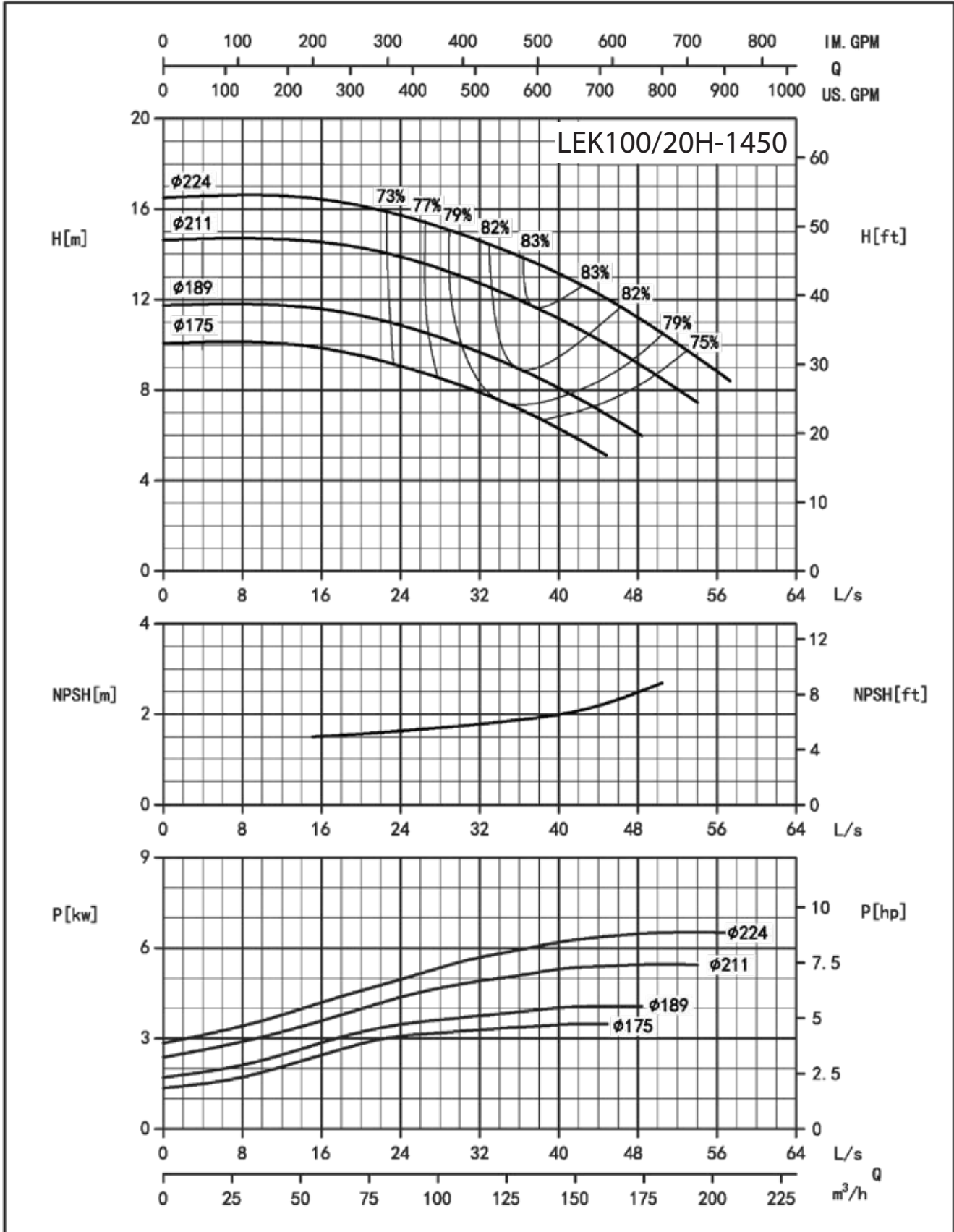

### END SUCTION PUMP PERFORMANCE CURVE LEK SERIES

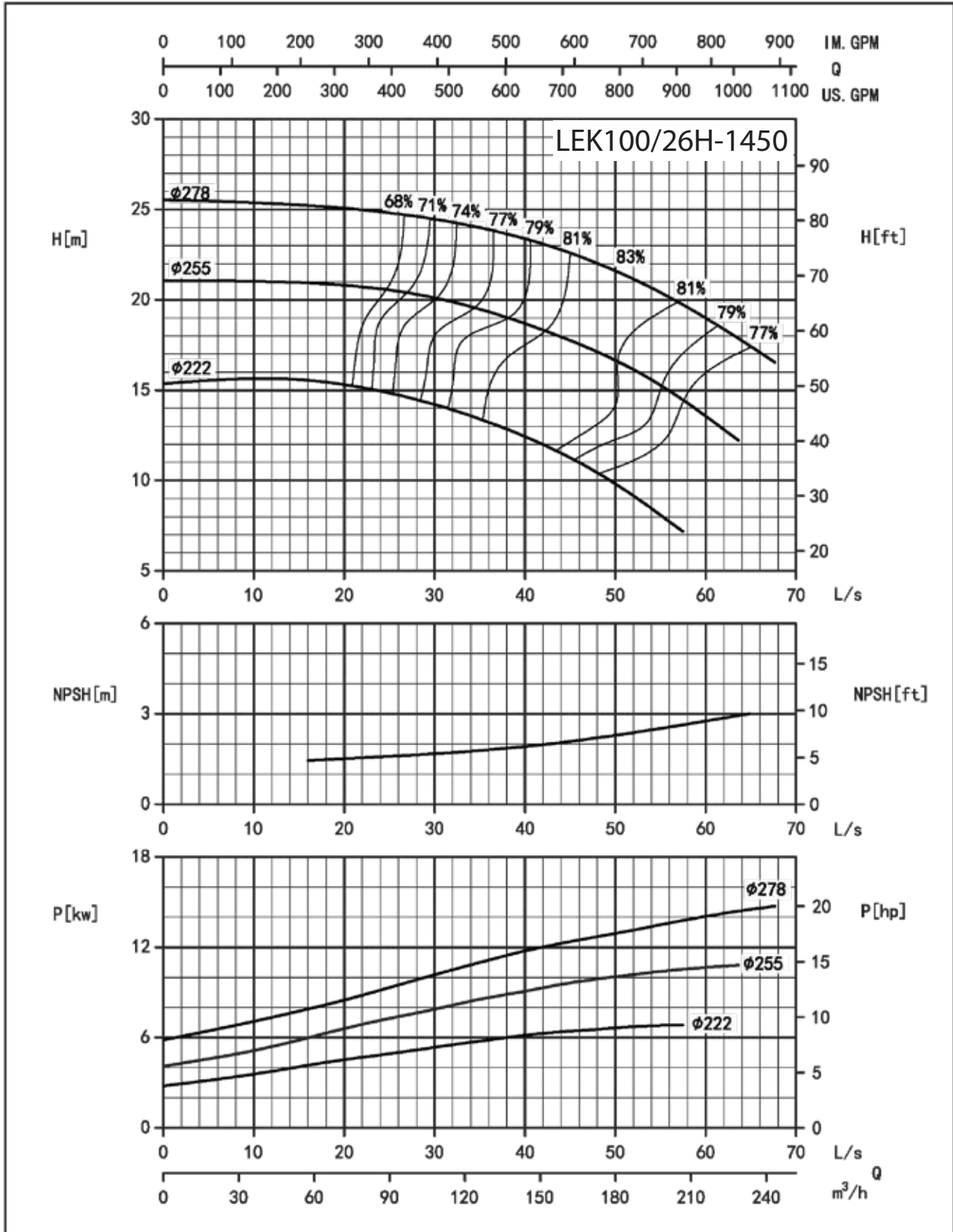

## END SUCTION PUMP PERFORMANCE CURVE LEK SERIES

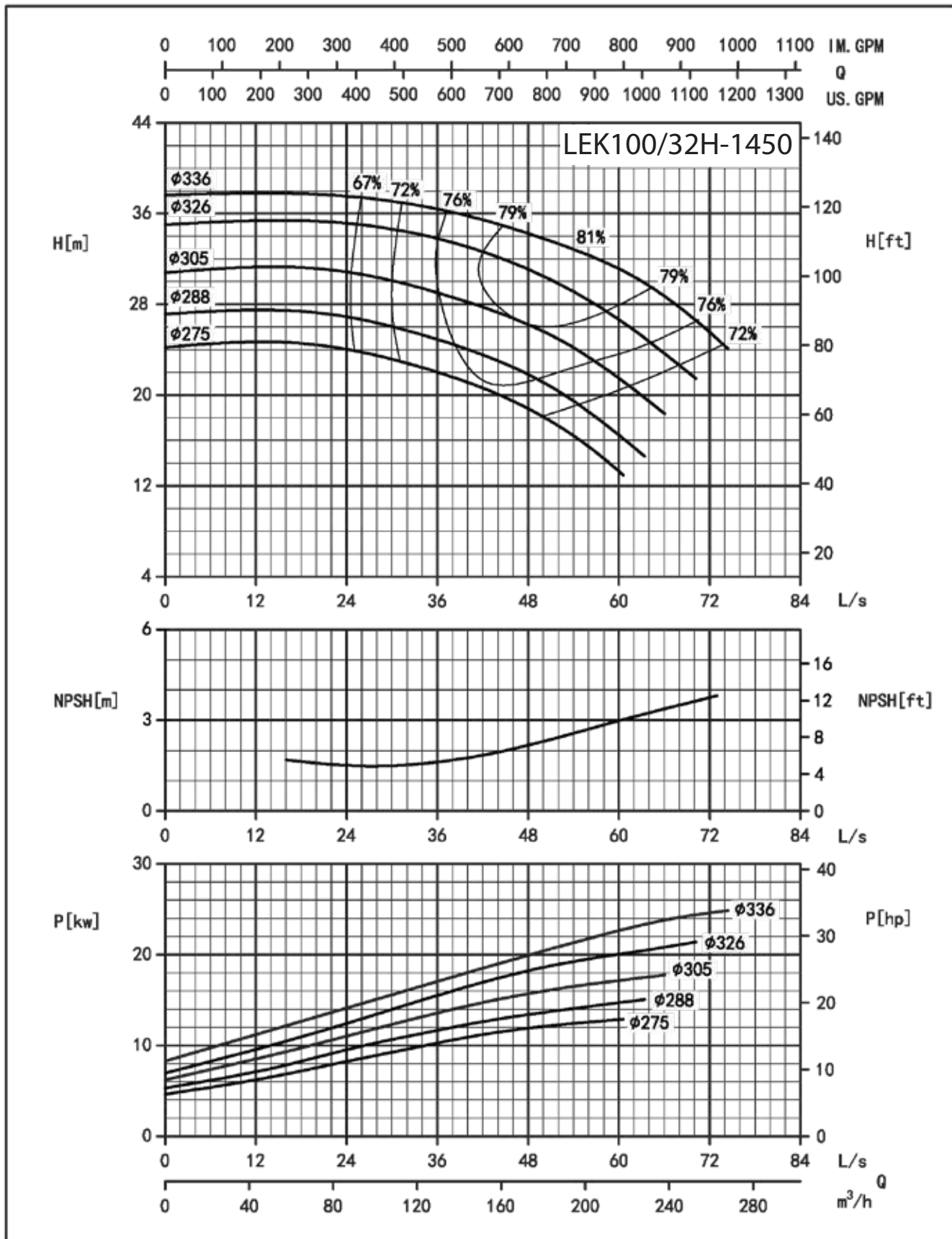

### END SUCTION PUMP PERFORMANCE CURVE LEK SERIES

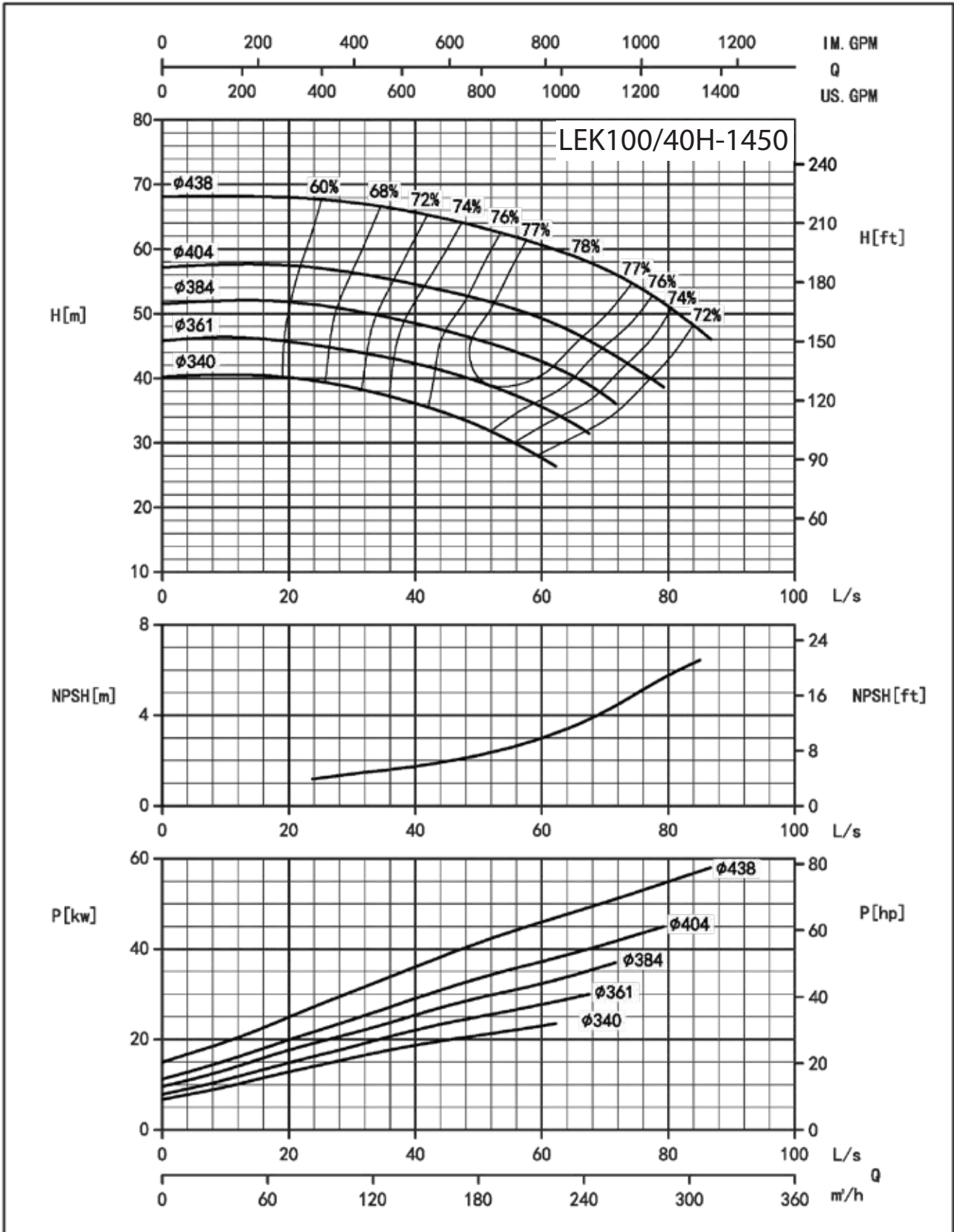

## END SUCTION PUMP PERFORMANCE CURVE LEK SERIES

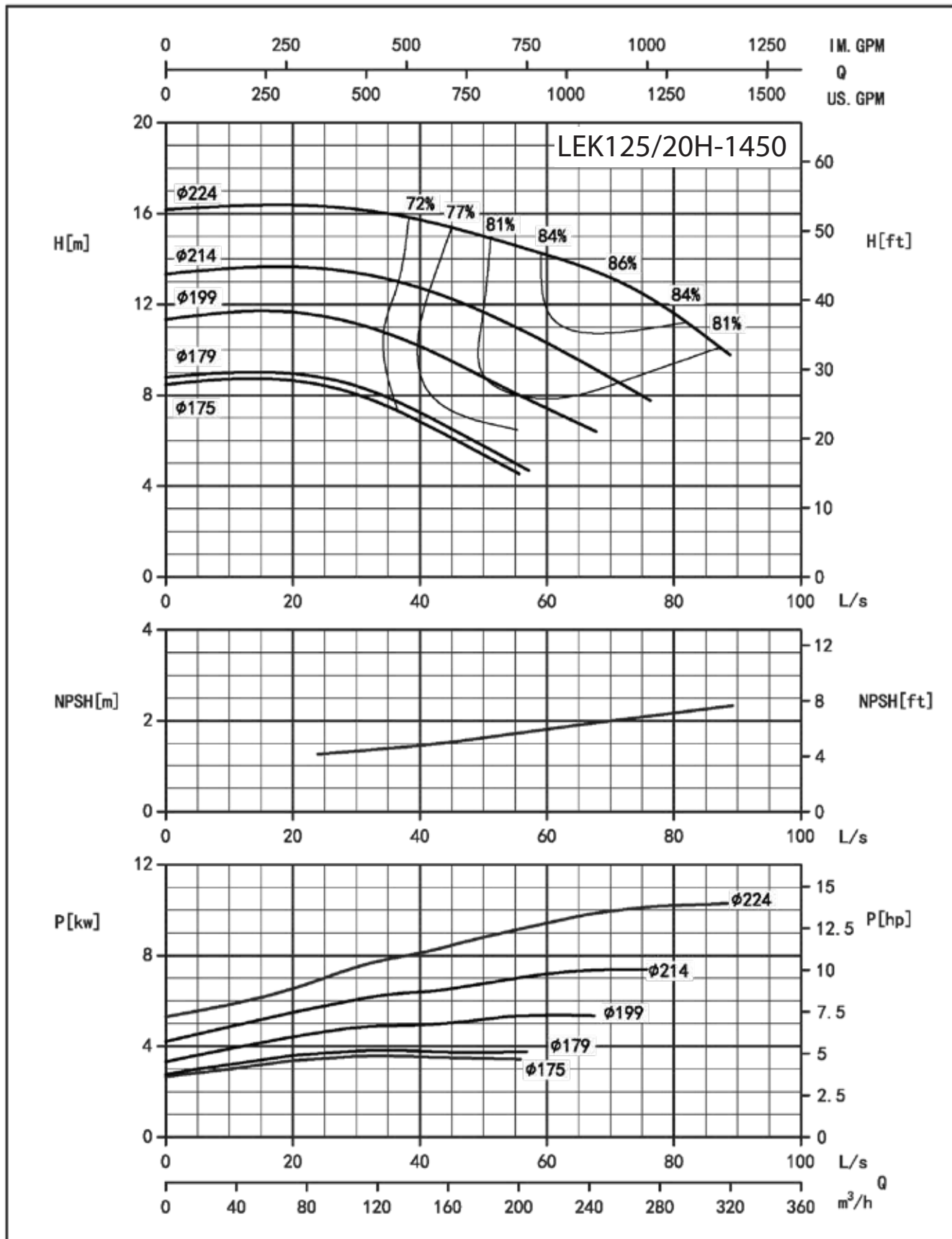

### END SUCTION PUMP PERFORMANCE CURVE LEK SERIES

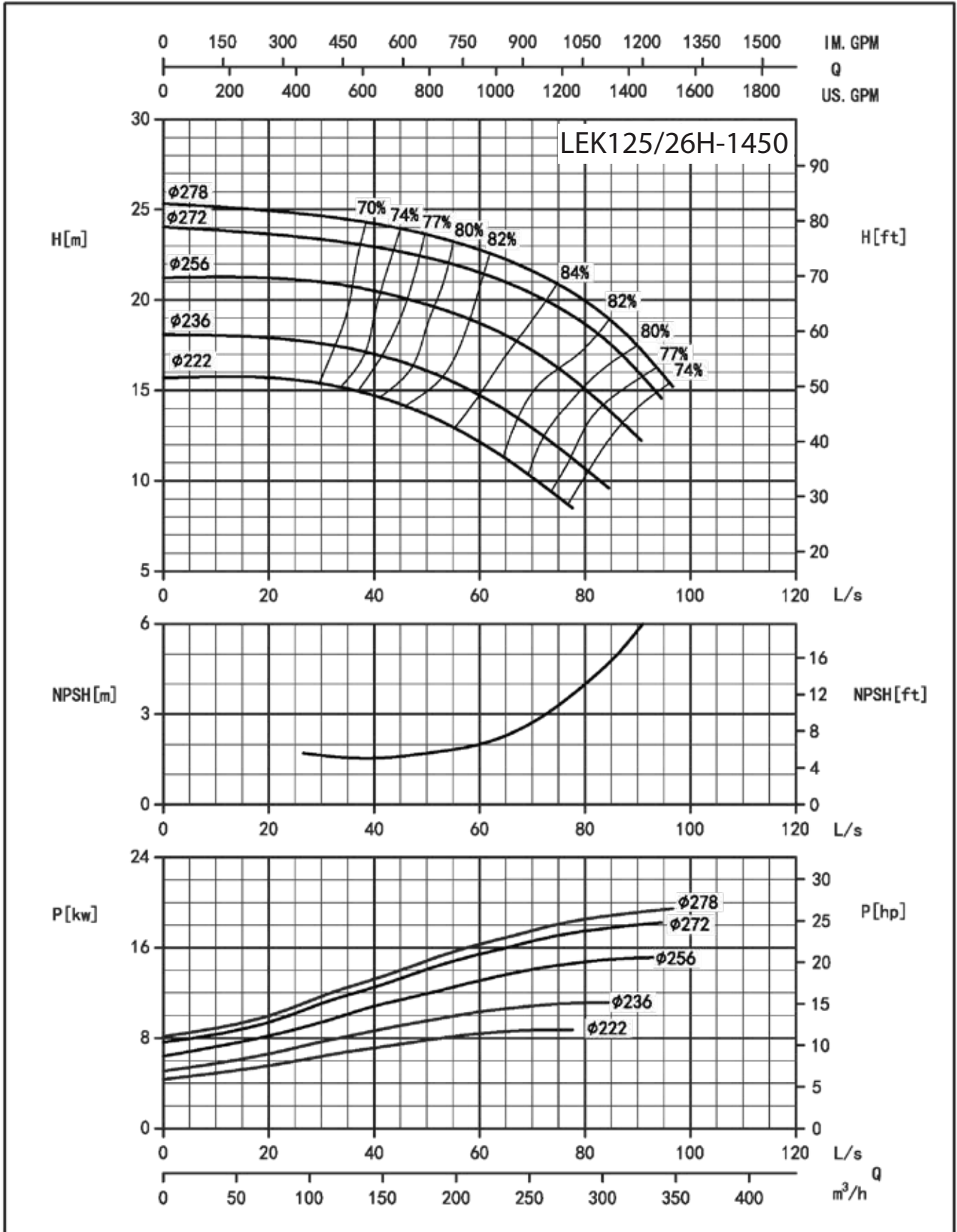

## END SUCTION PUMP PERFORMANCE CURVE LEK SERIES

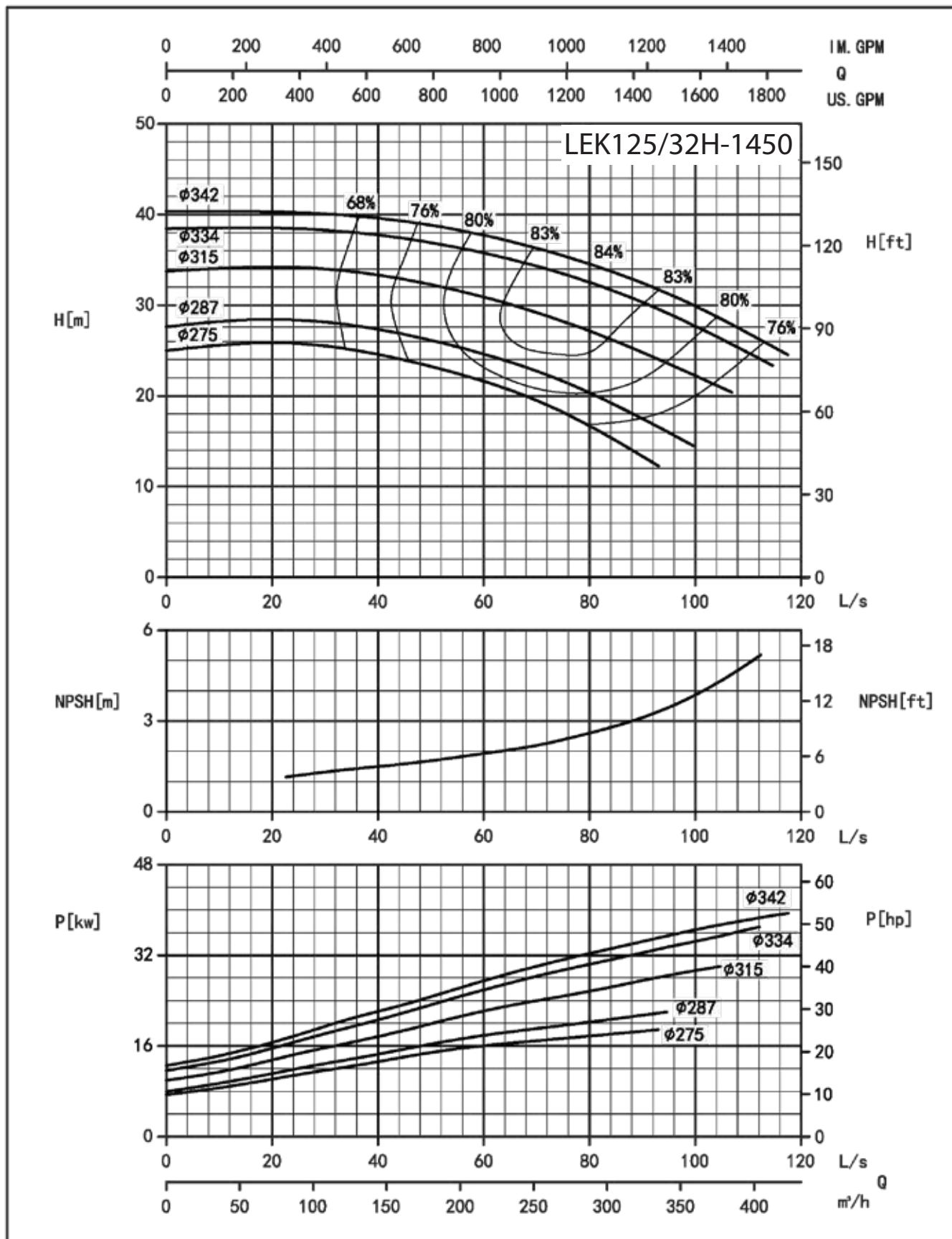

### END SUCTION PUMP PERFORMANCE CURVE LEK SERIES

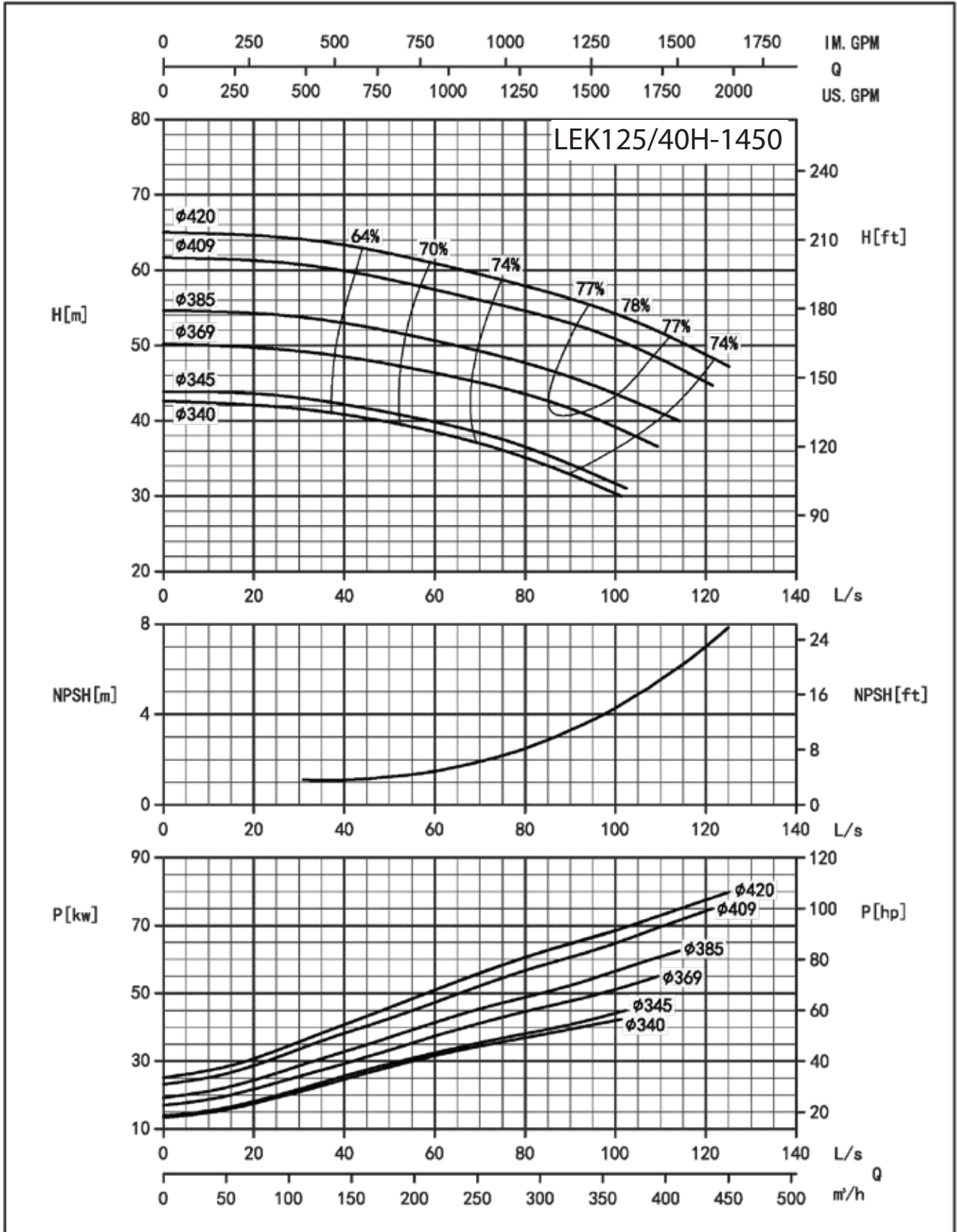

**END SUCTION PUMP PERFORMANCE CURVE  
LEK SERIES**

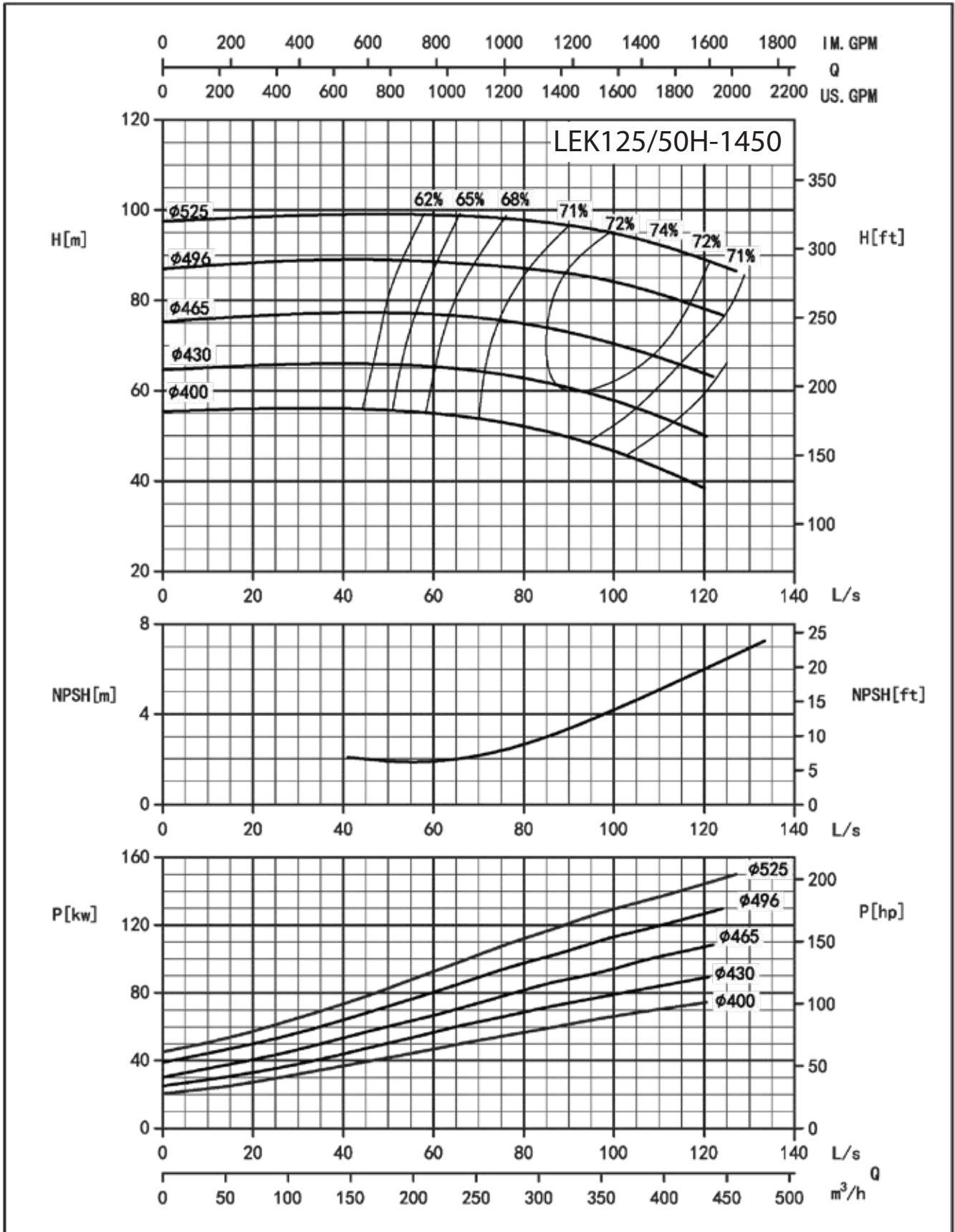

### END SUCTION PUMP PERFORMANCE CURVE LEK SERIES

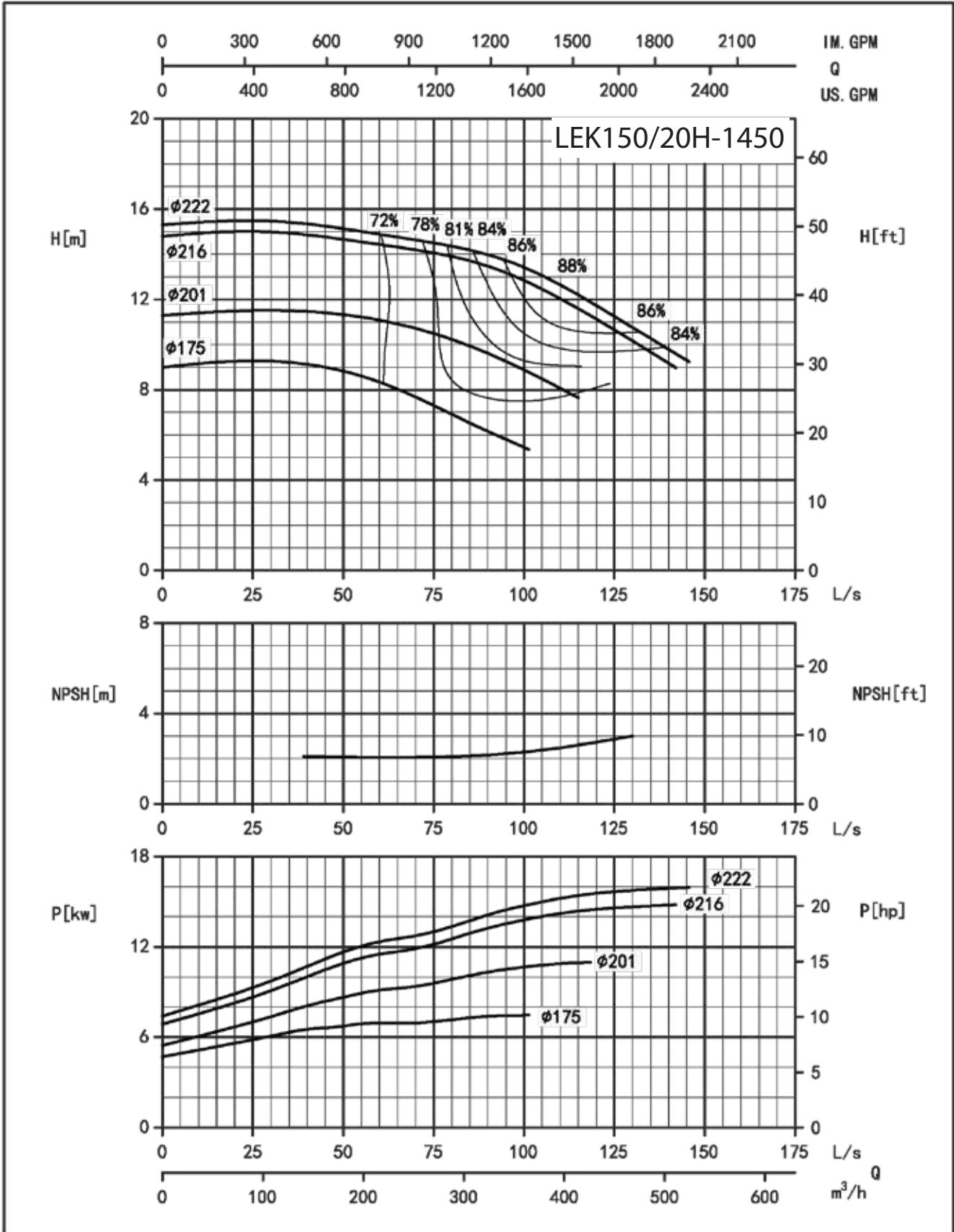

**END SUCTION PUMP PERFORMANCE CURVE  
LEK SERIES**

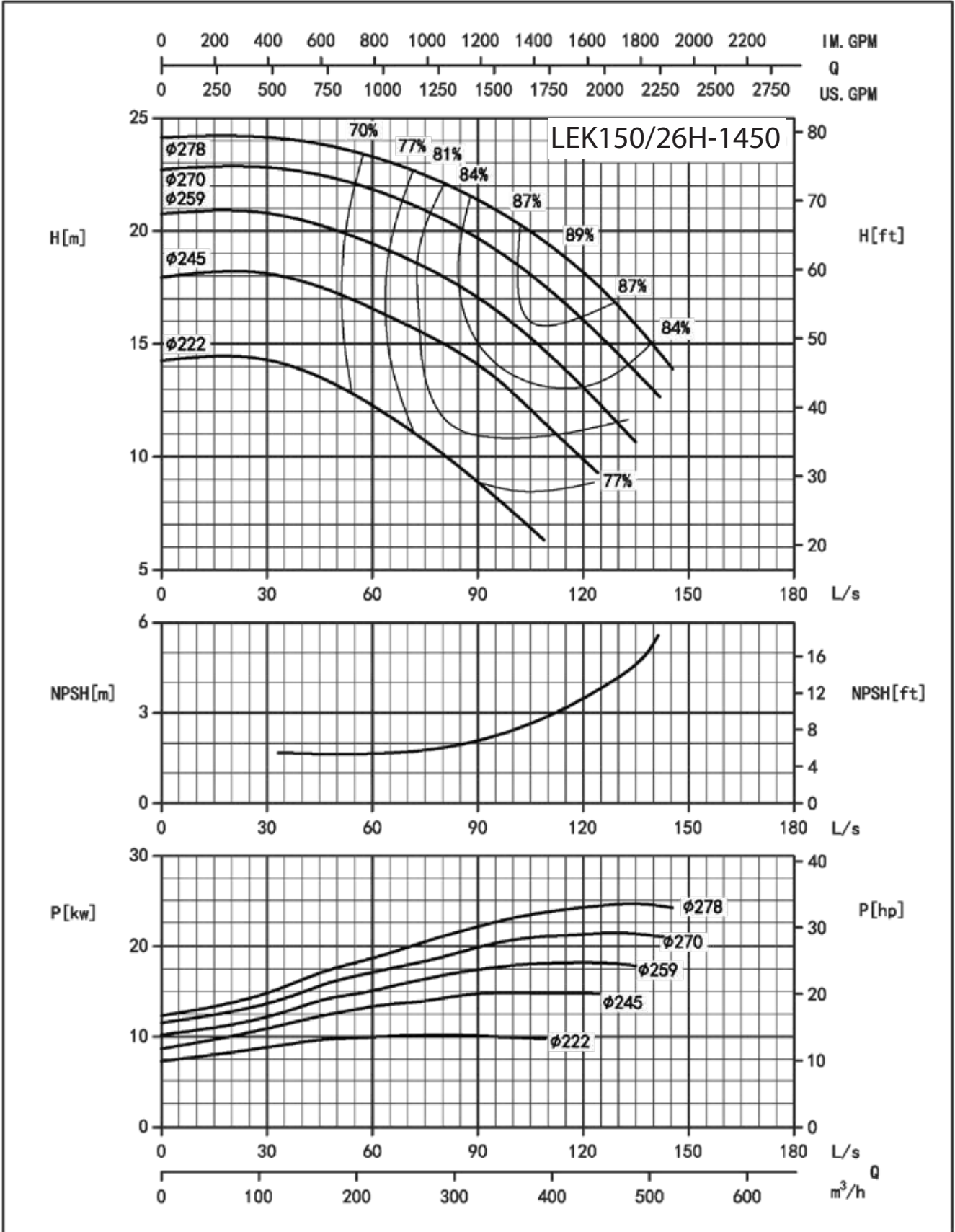

### END SUCTION PUMP PERFORMANCE CURVE LEK SERIES

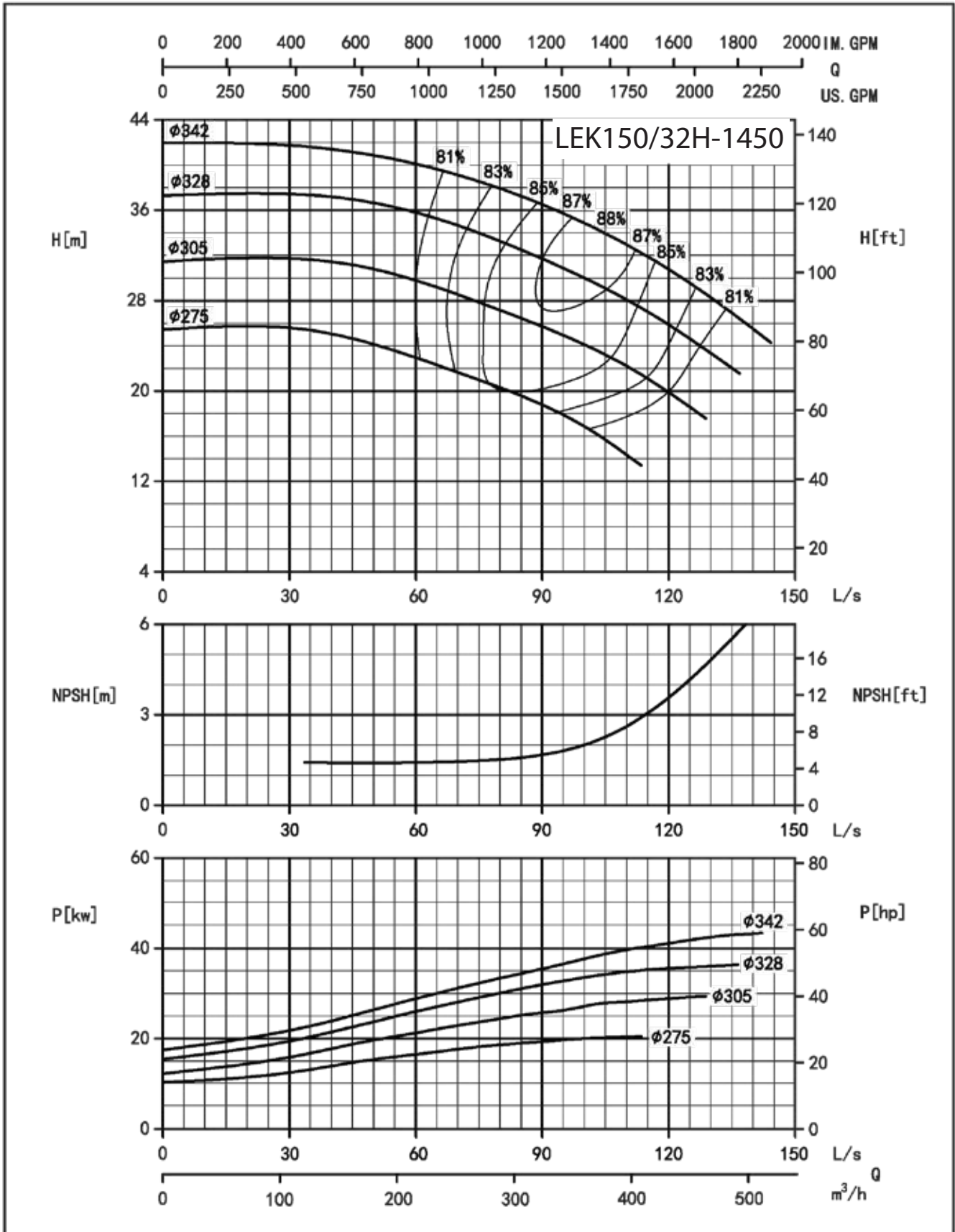

## END SUCTION PUMP PERFORMANCE CURVE LEK SERIES

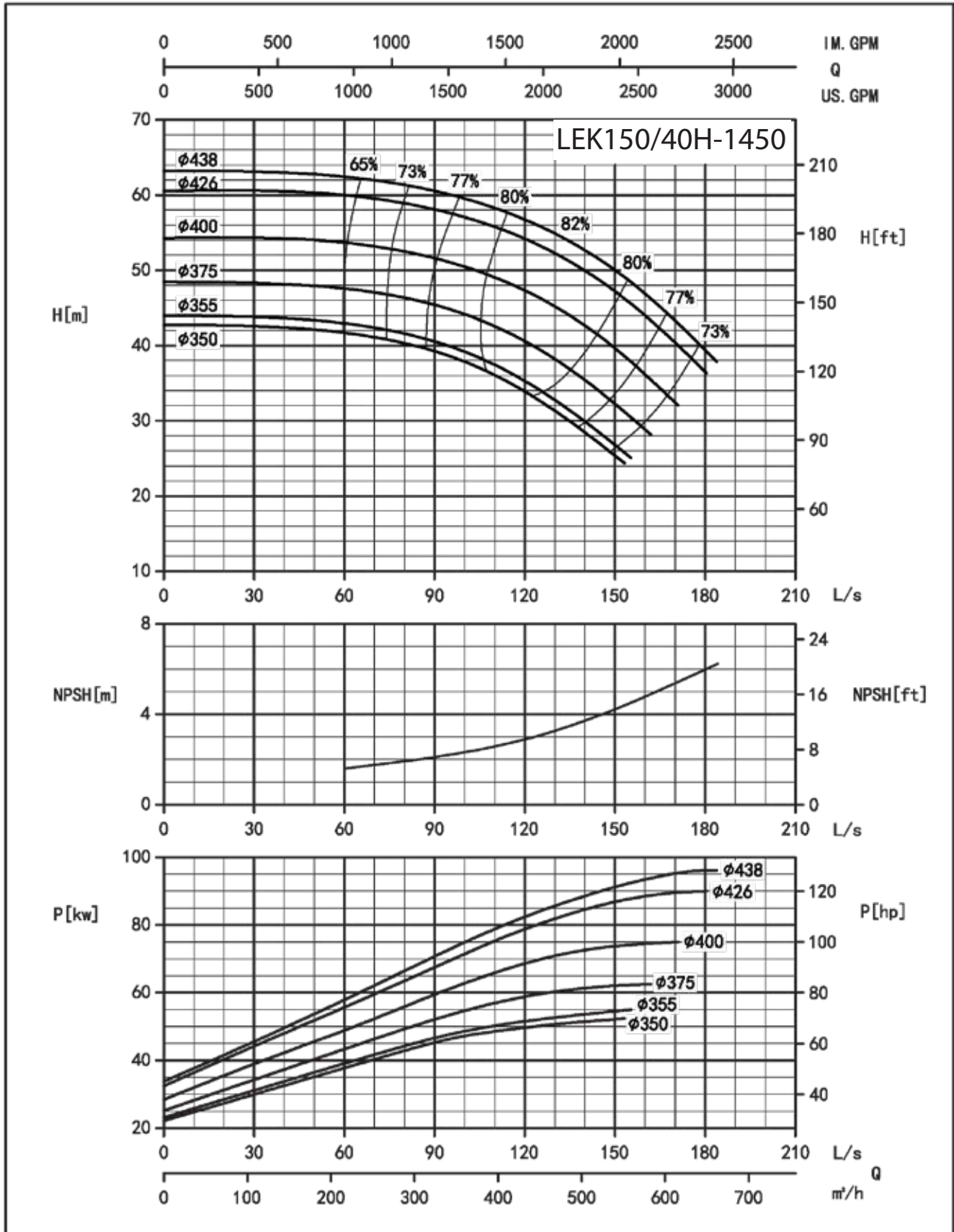

### END SUCTION PUMP PERFORMANCE CURVE LEK SERIES

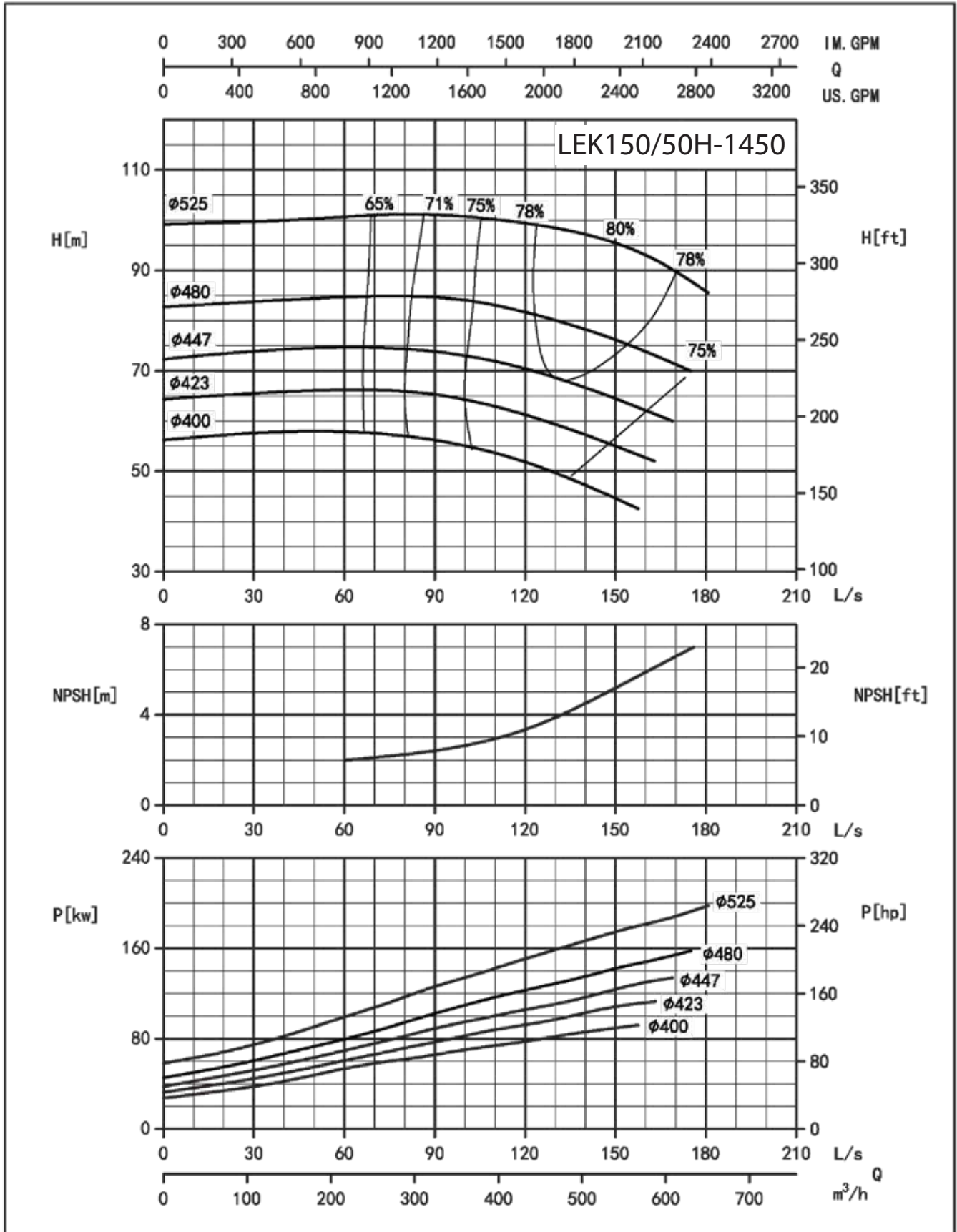

## END SUCTION PUMP PERFORMANCE CURVE LEK SERIES

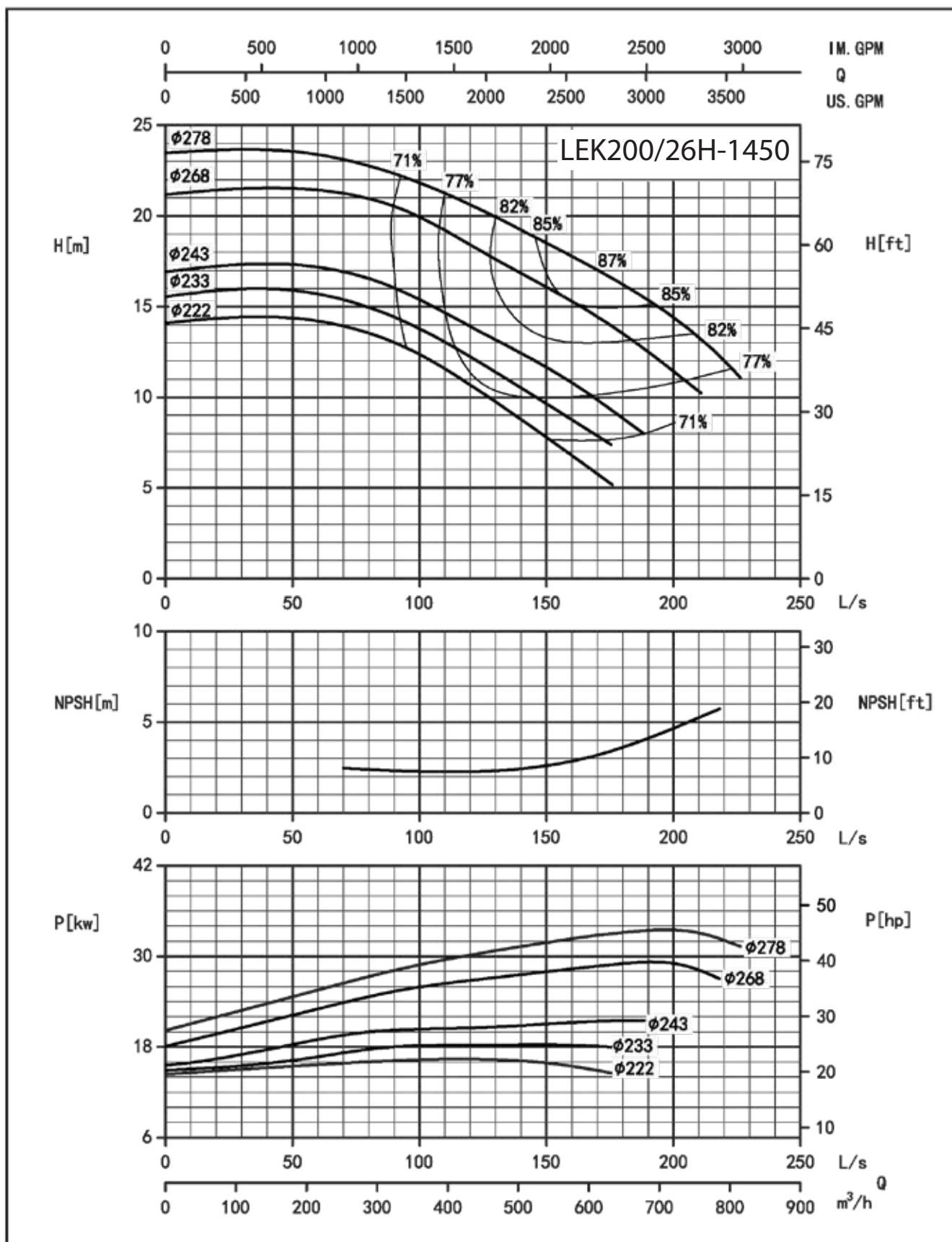

## END SUCTION PUMP PERFORMANCE CURVE LEK SERIES

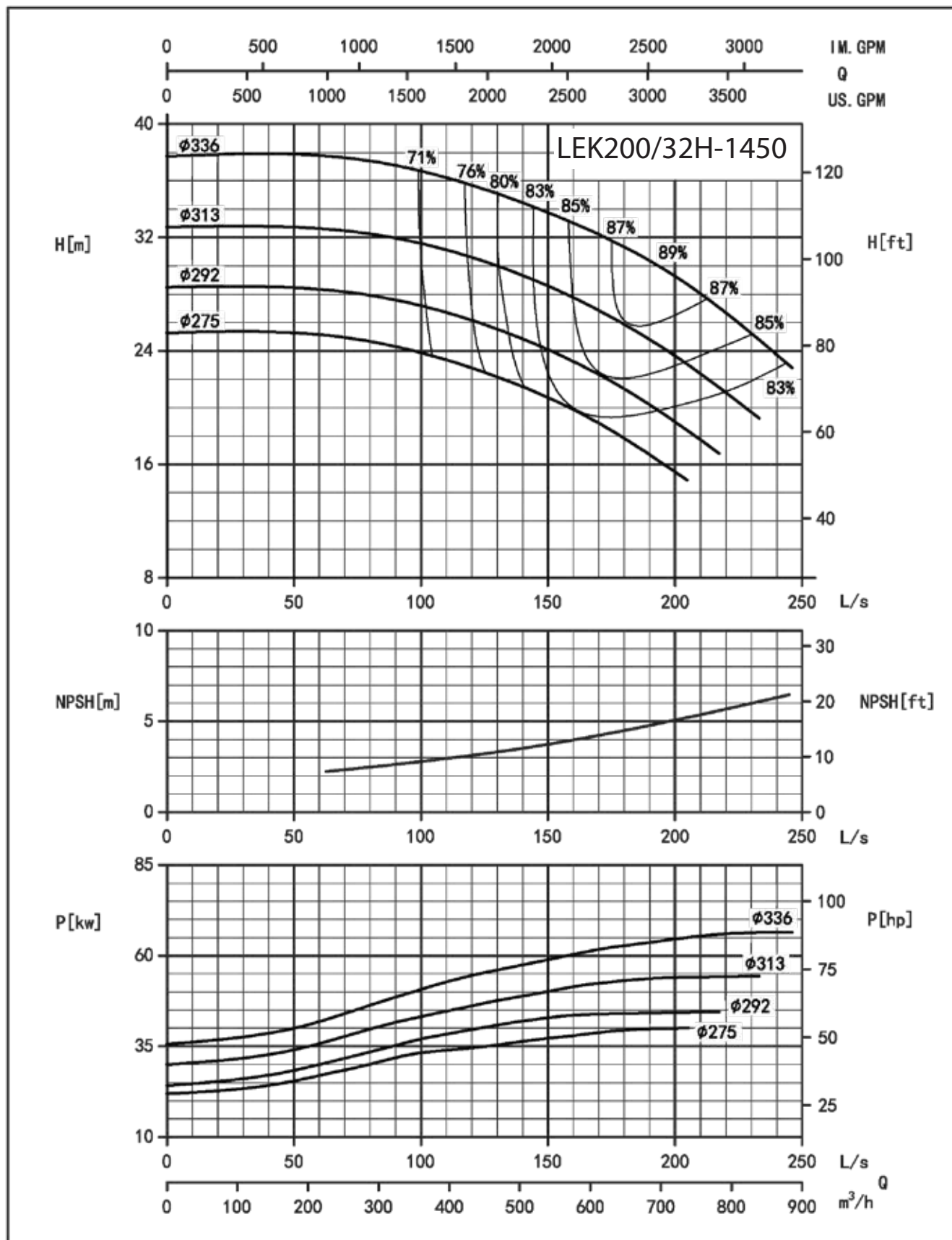

### END SUCTION PUMP PERFORMANCE CURVE LEK SERIES

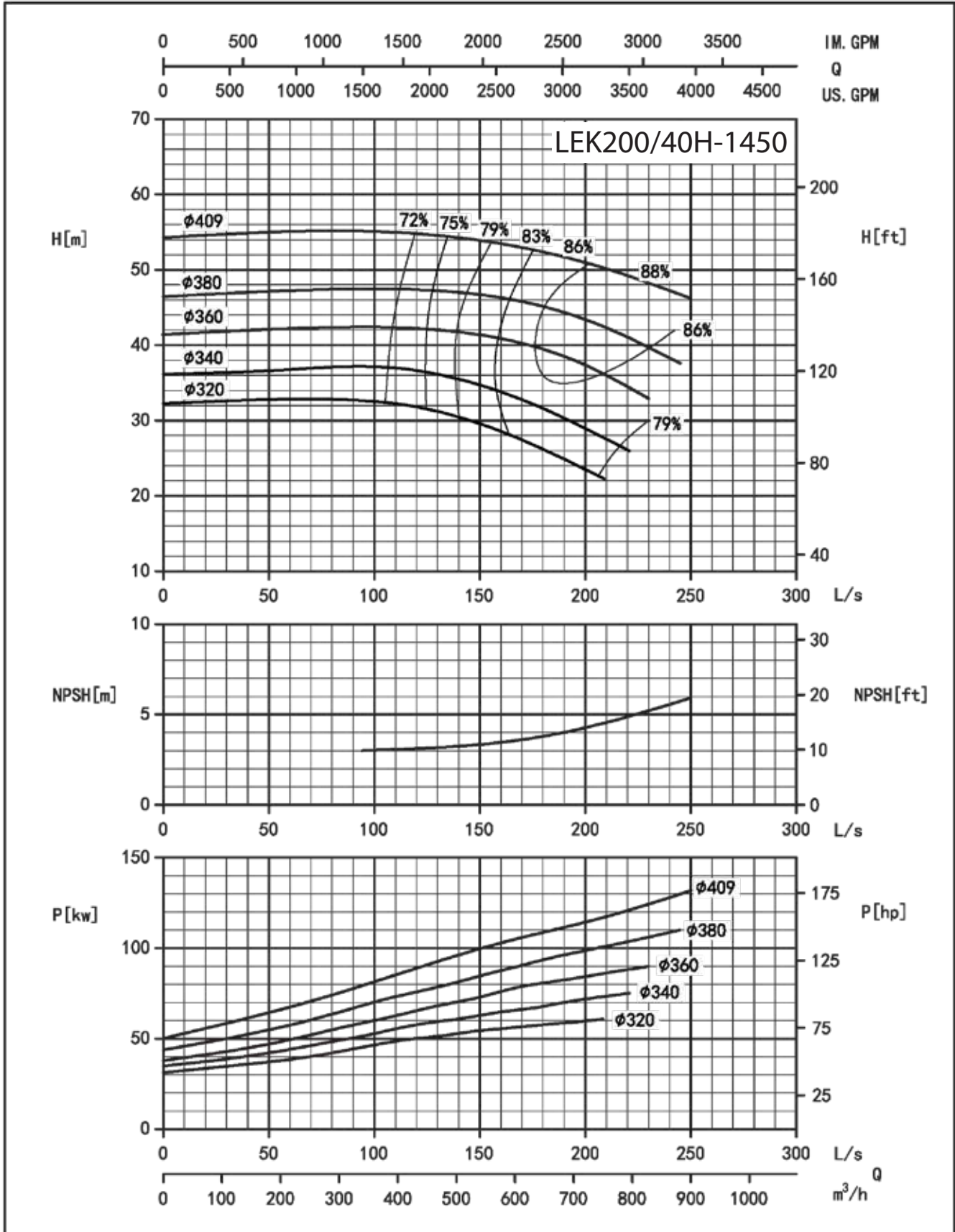

## END SUCTION PUMP PERFORMANCE CURVE LEK SERIES

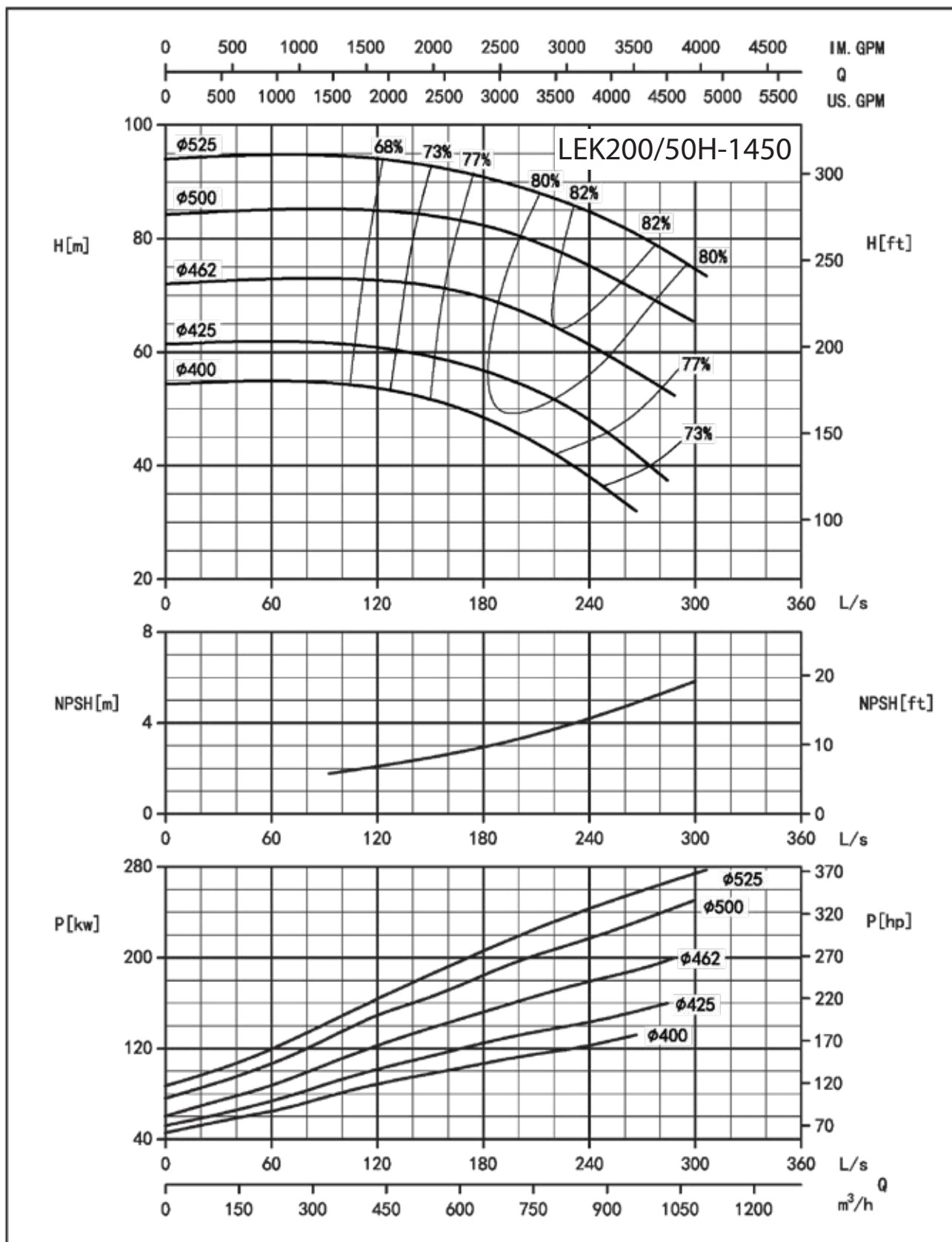

### END SUCTION PUMP PERFORMANCE CURVE LEK SERIES

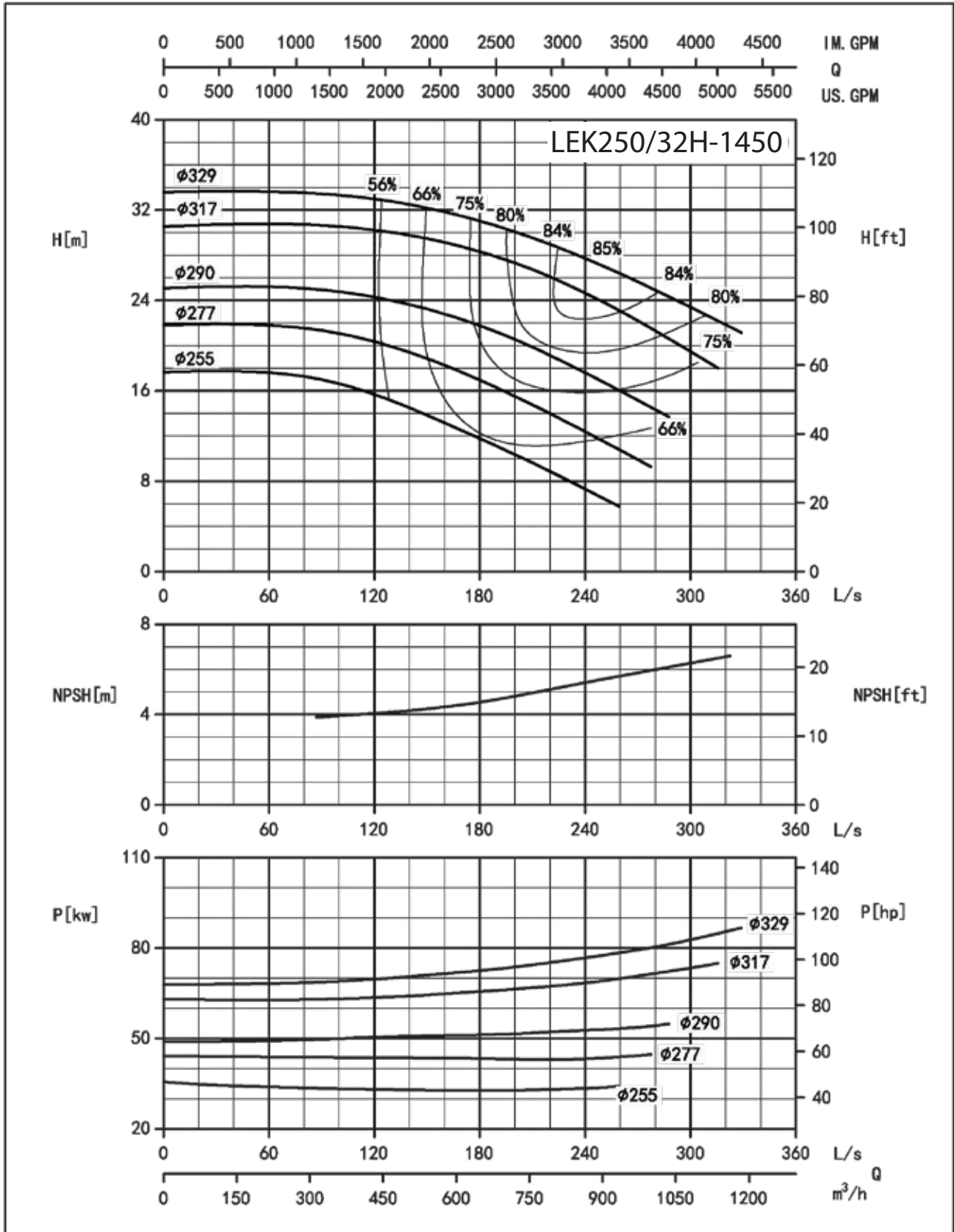

## END SUCTION PUMP PERFORMANCE CURVE LEK SERIES

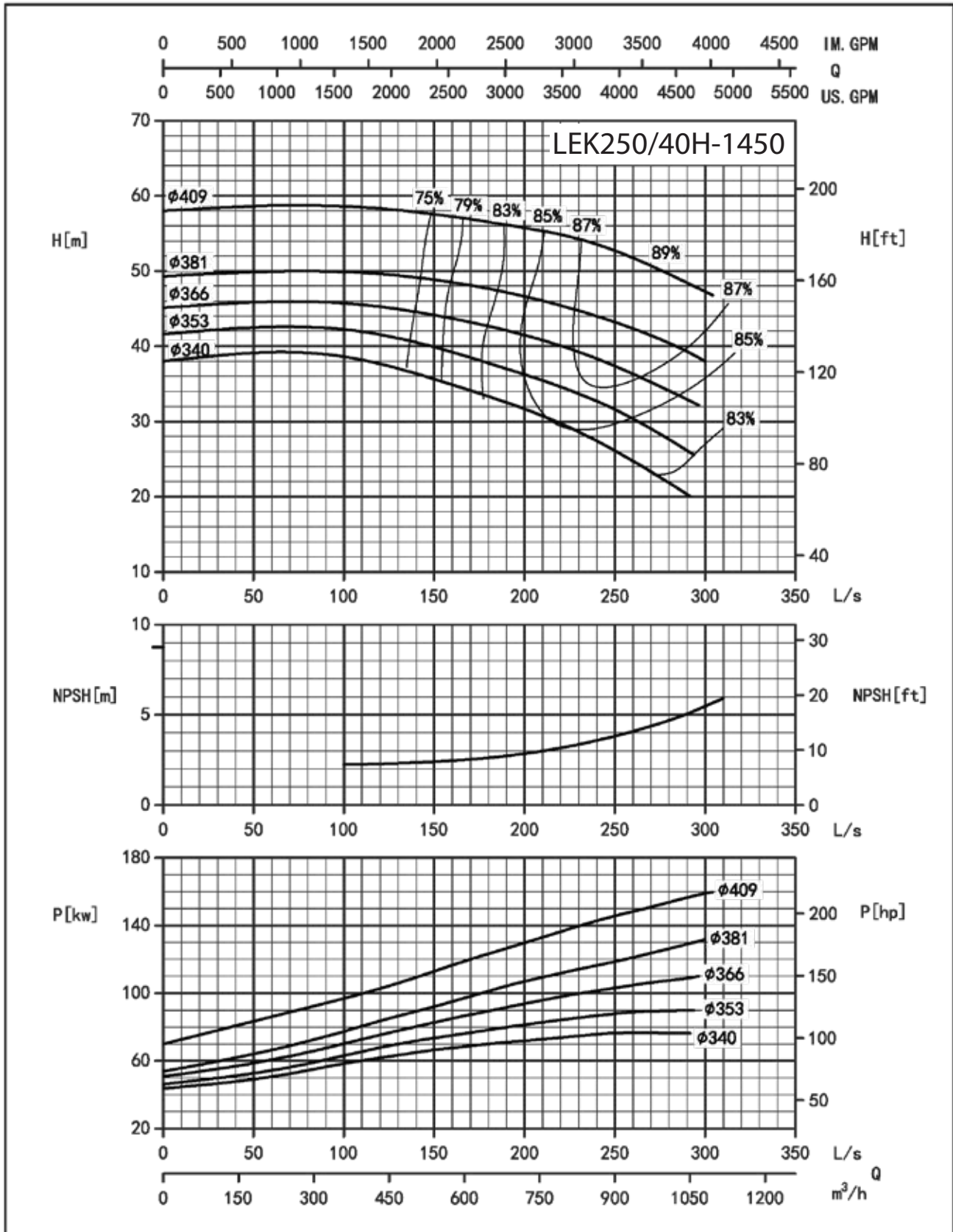

### END SUCTION PUMP PERFORMANCE CURVE LEK SERIES

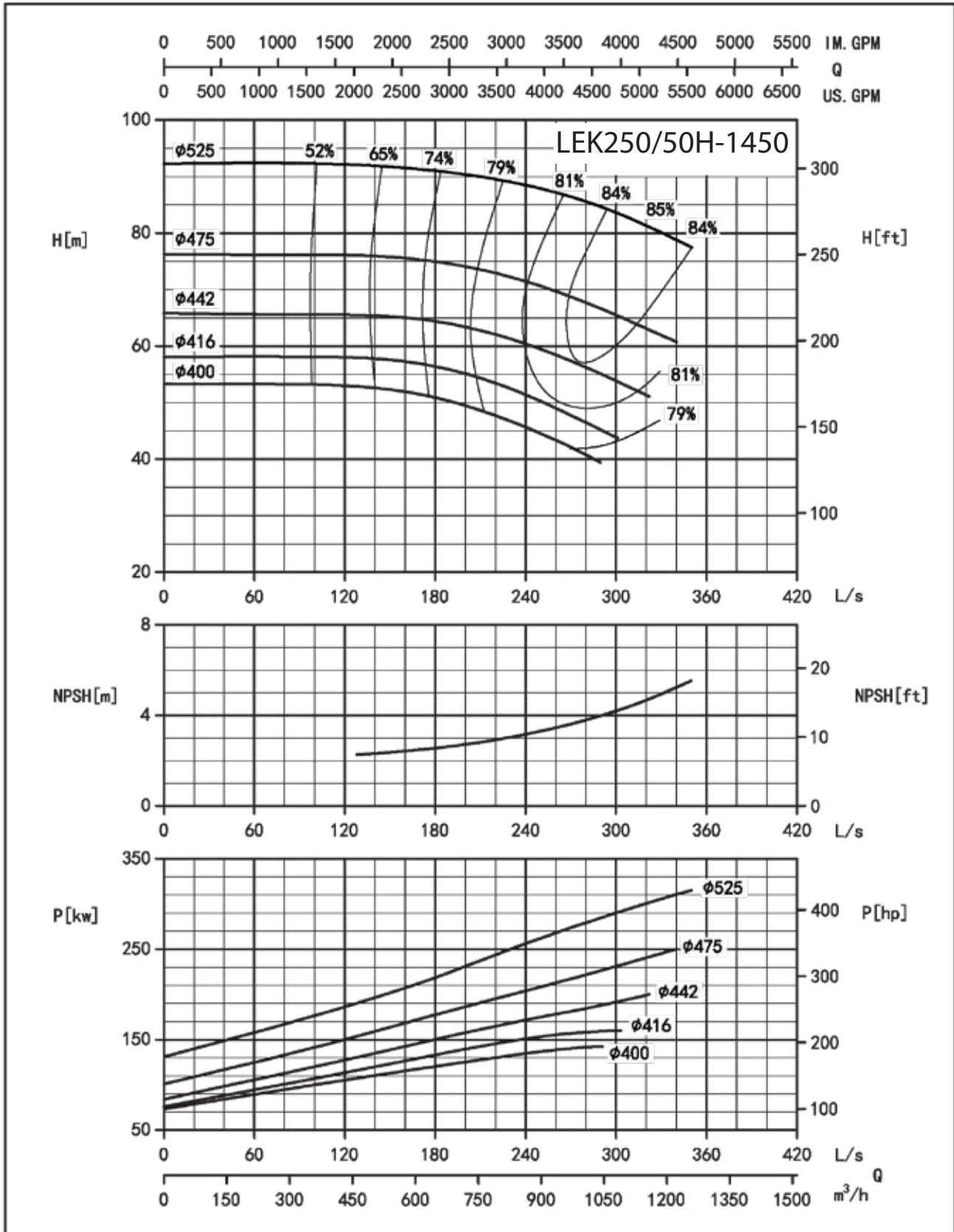

**END SUCTION PUMP PERFORMANCE CURVE  
LEK SERIES**

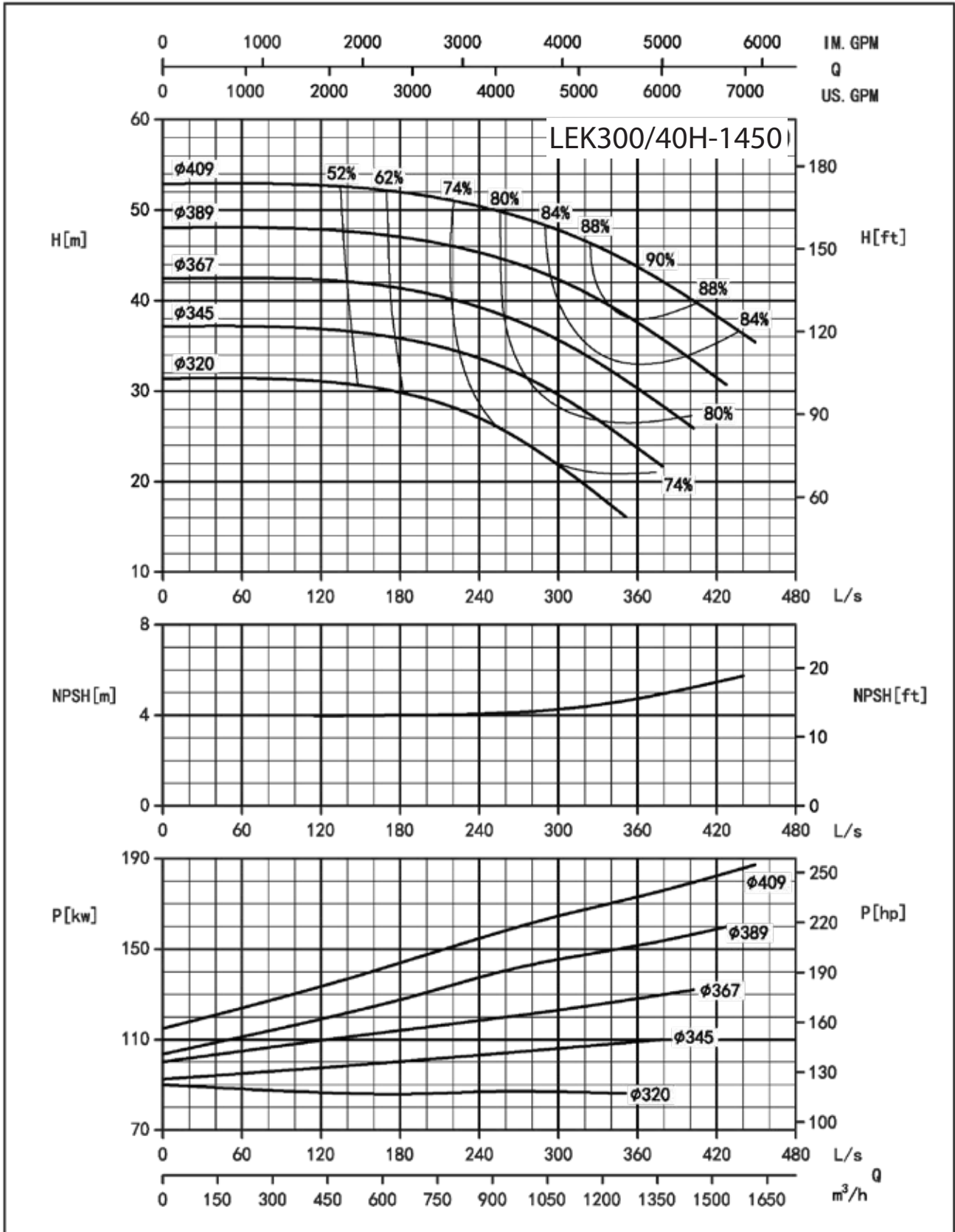

### END SUCTION PUMP PERFORMANCE CURVE LEK SERIES

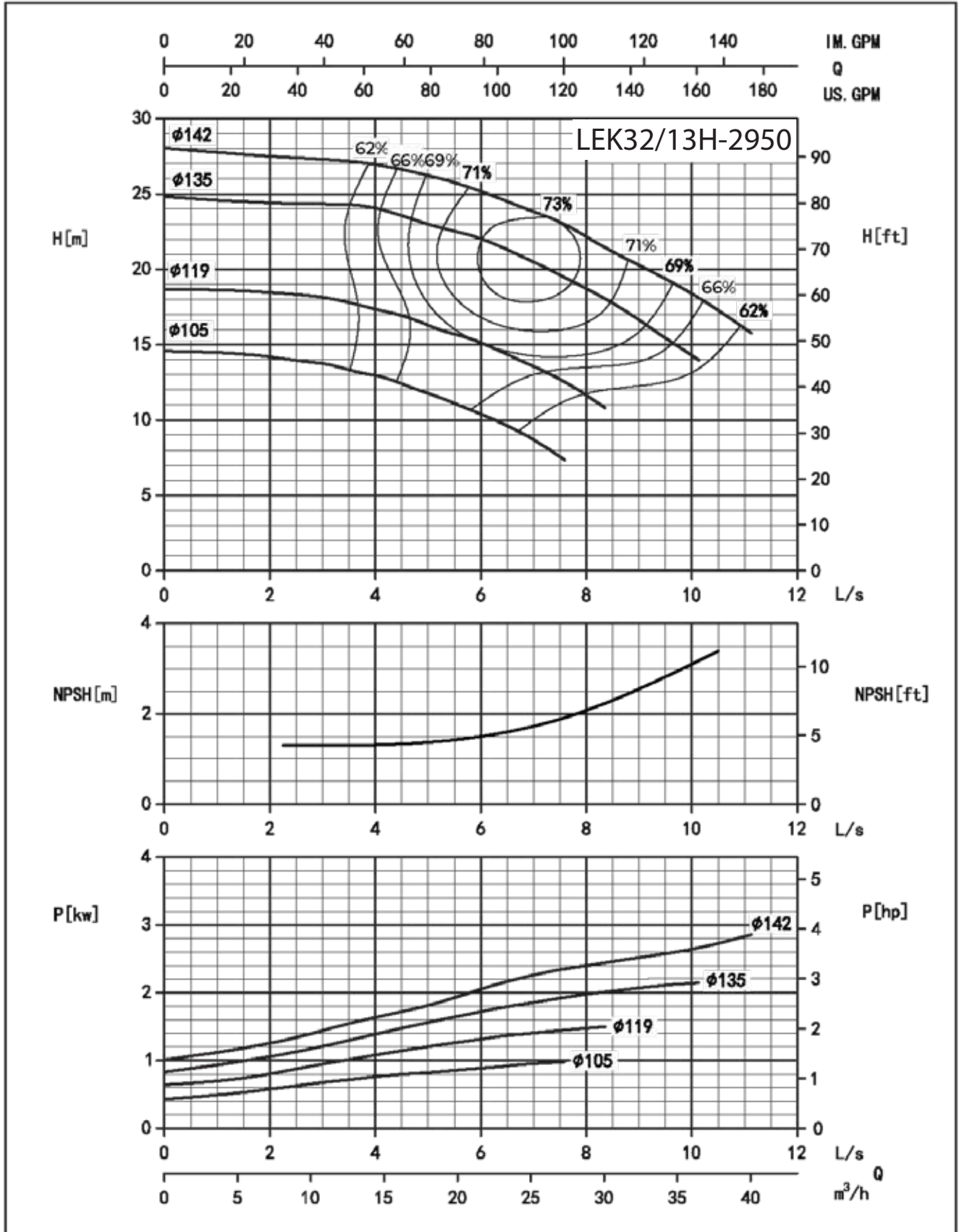

**END SUCTION PUMP PERFORMANCE CURVE  
LEK SERIES**

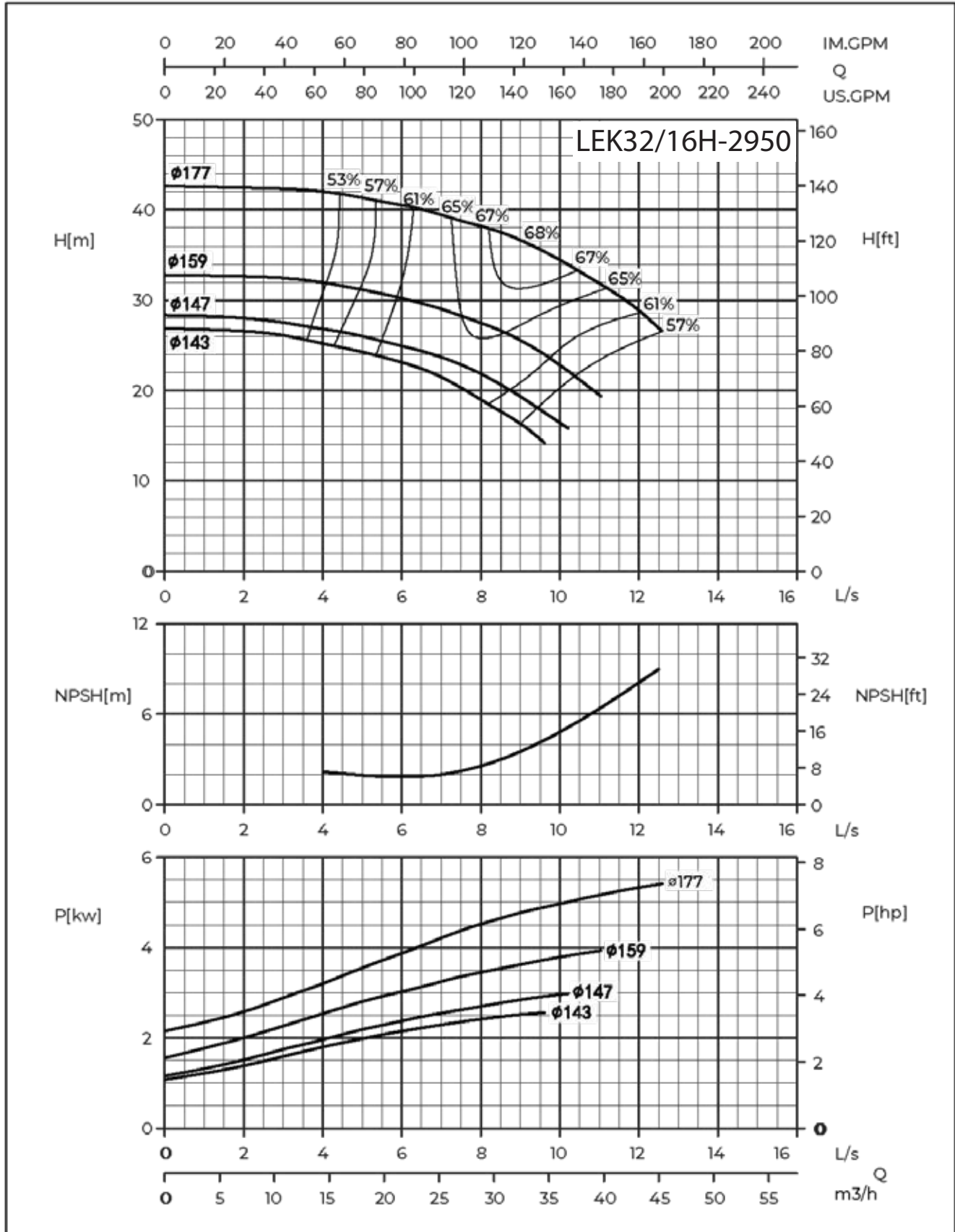

### END SUCTION PUMP PERFORMANCE CURVE LEK SERIES

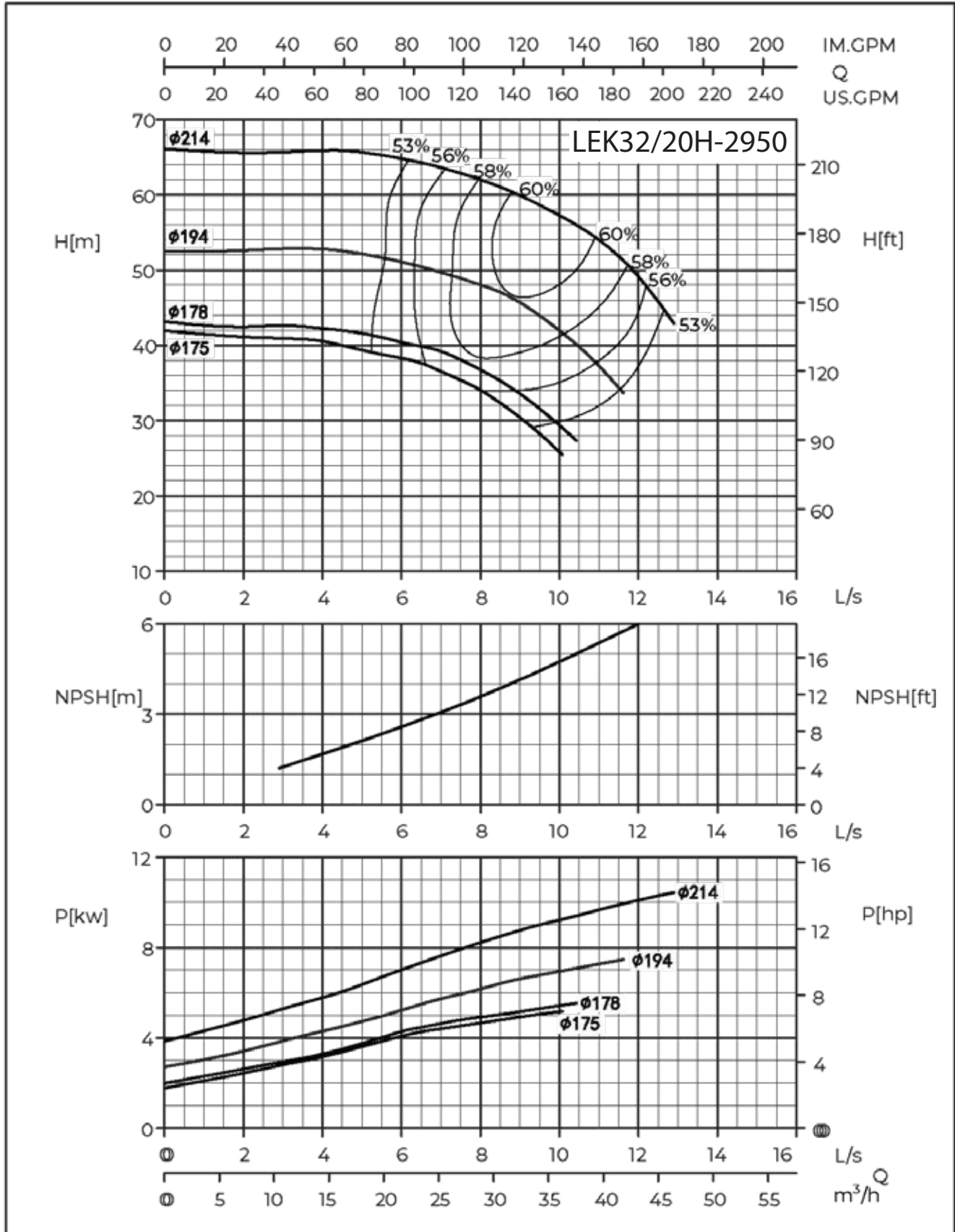

## END SUCTION PUMP PERFORMANCE CURVE LEK SERIES

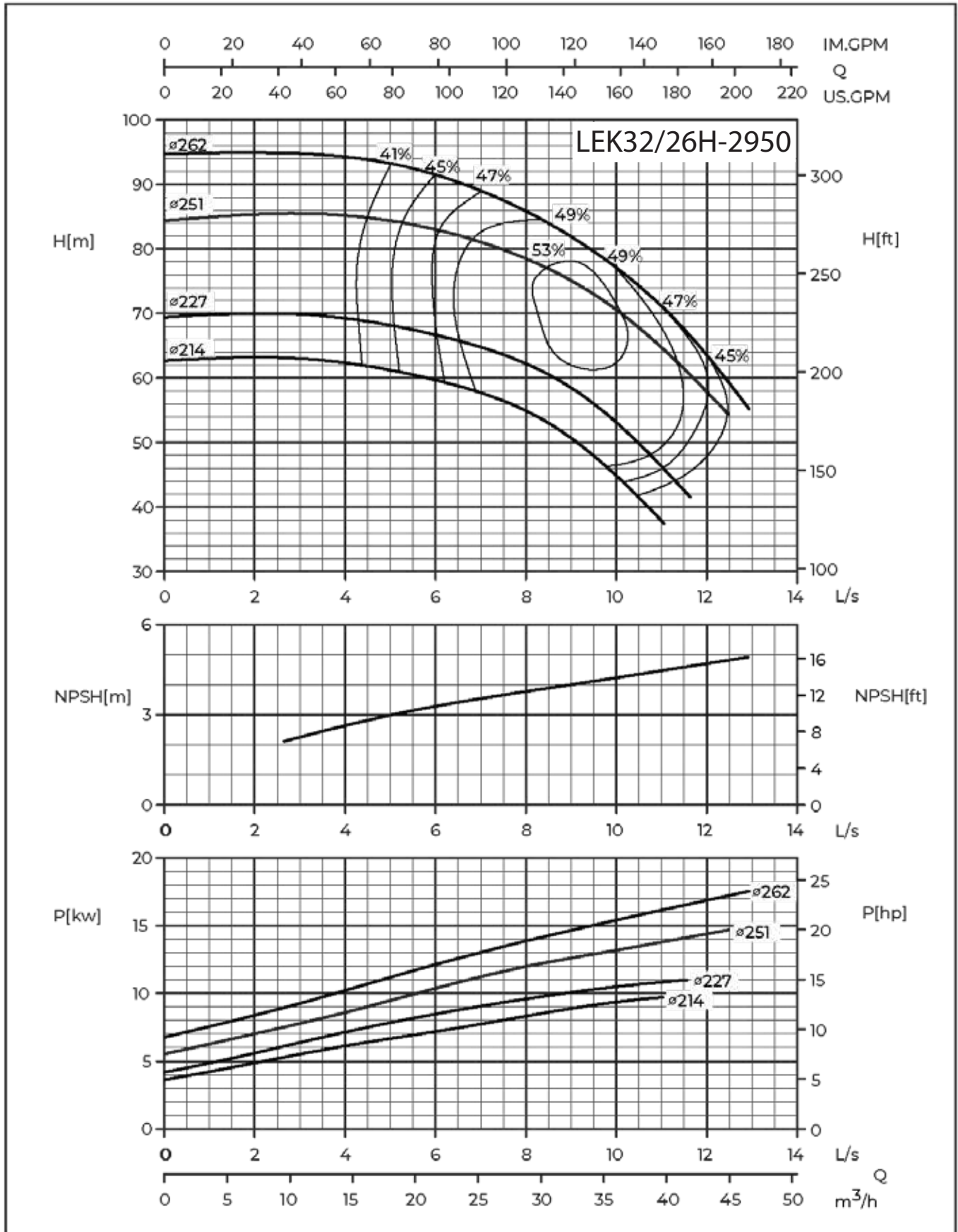

### END SUCTION PUMP PERFORMANCE CURVE LEK SERIES

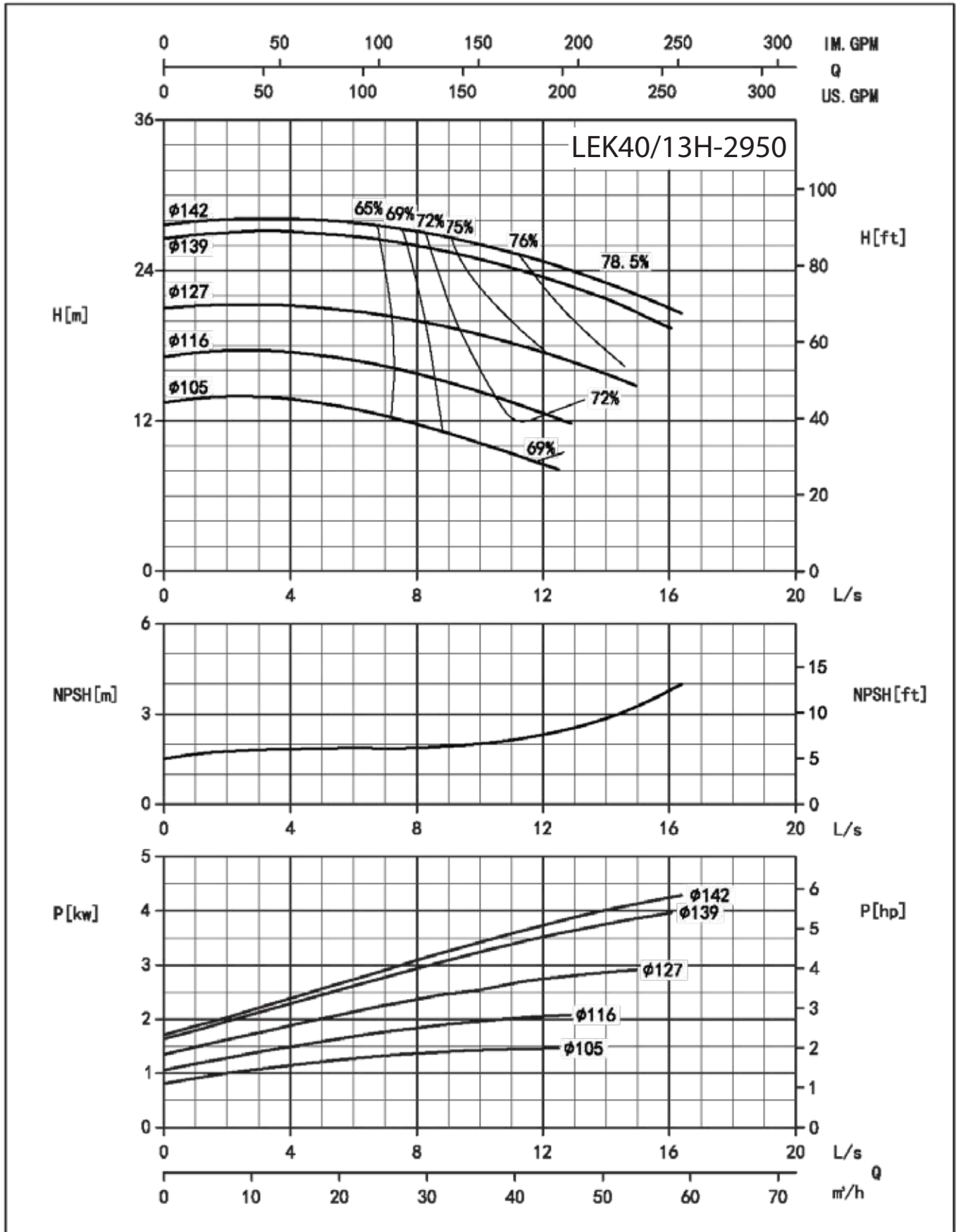

## END SUCTION PUMP PERFORMANCE CURVE LEK SERIES

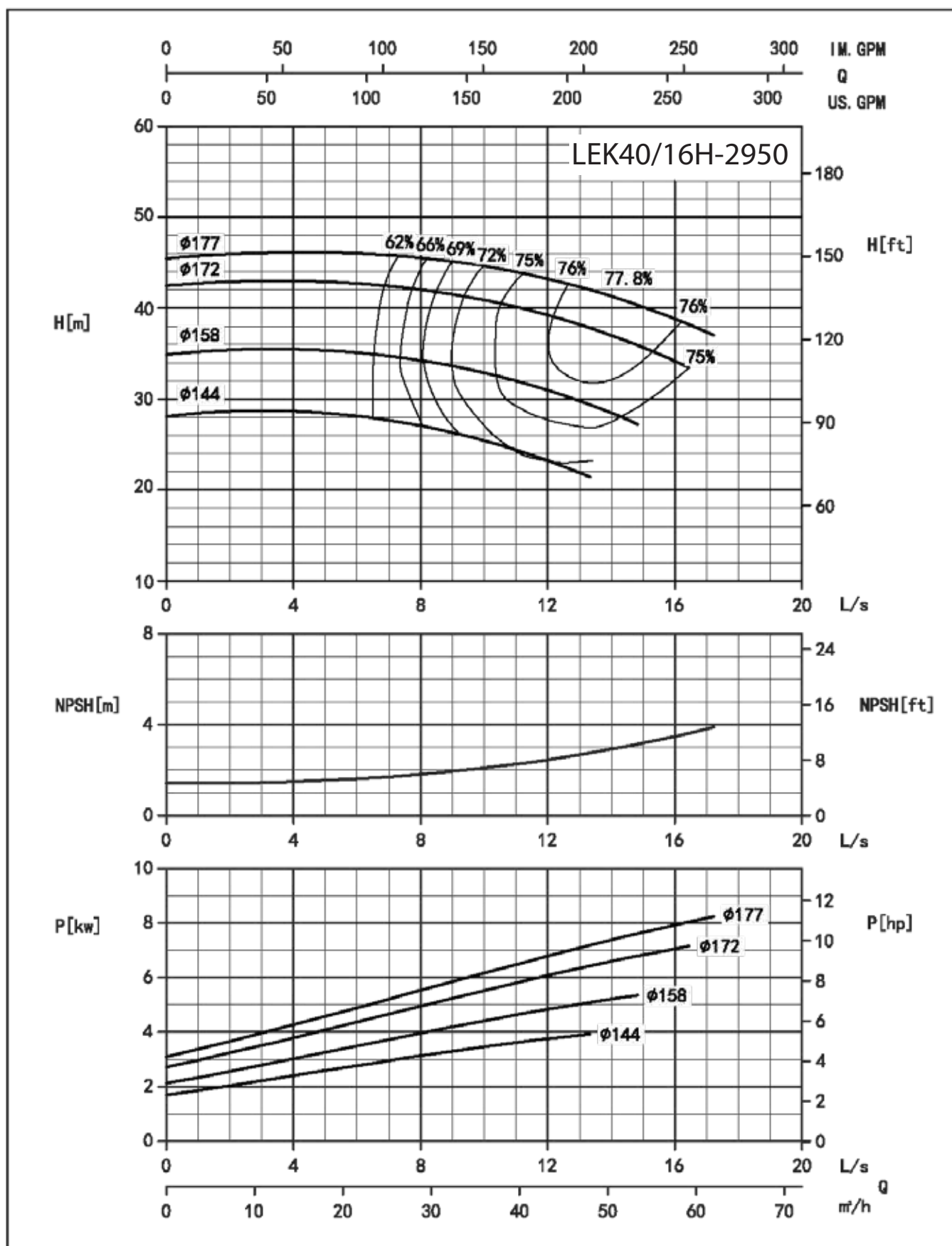

### END SUCTION PUMP PERFORMANCE CURVE LEK SERIES

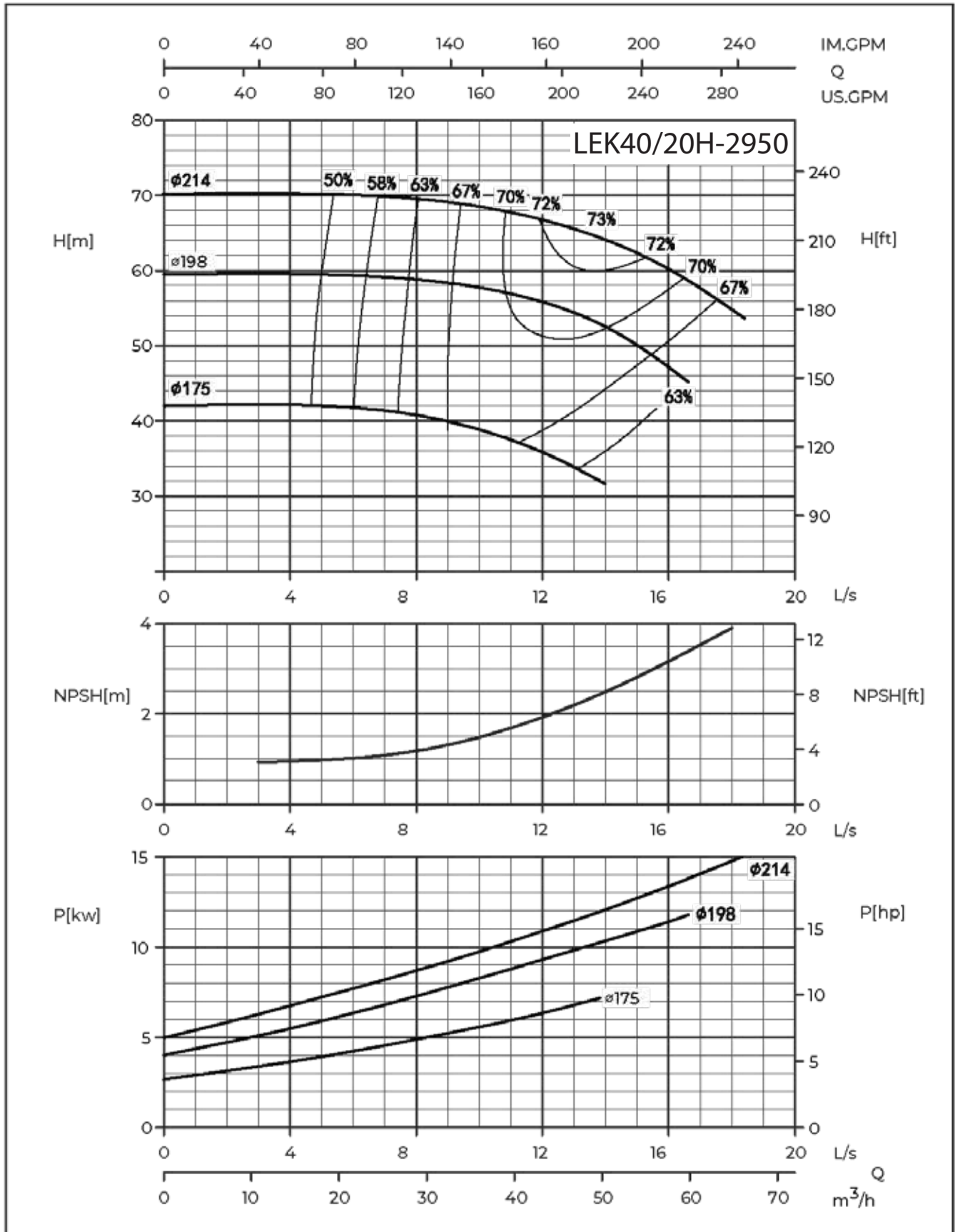

## END SUCTION PUMP PERFORMANCE CURVE LEK SERIES

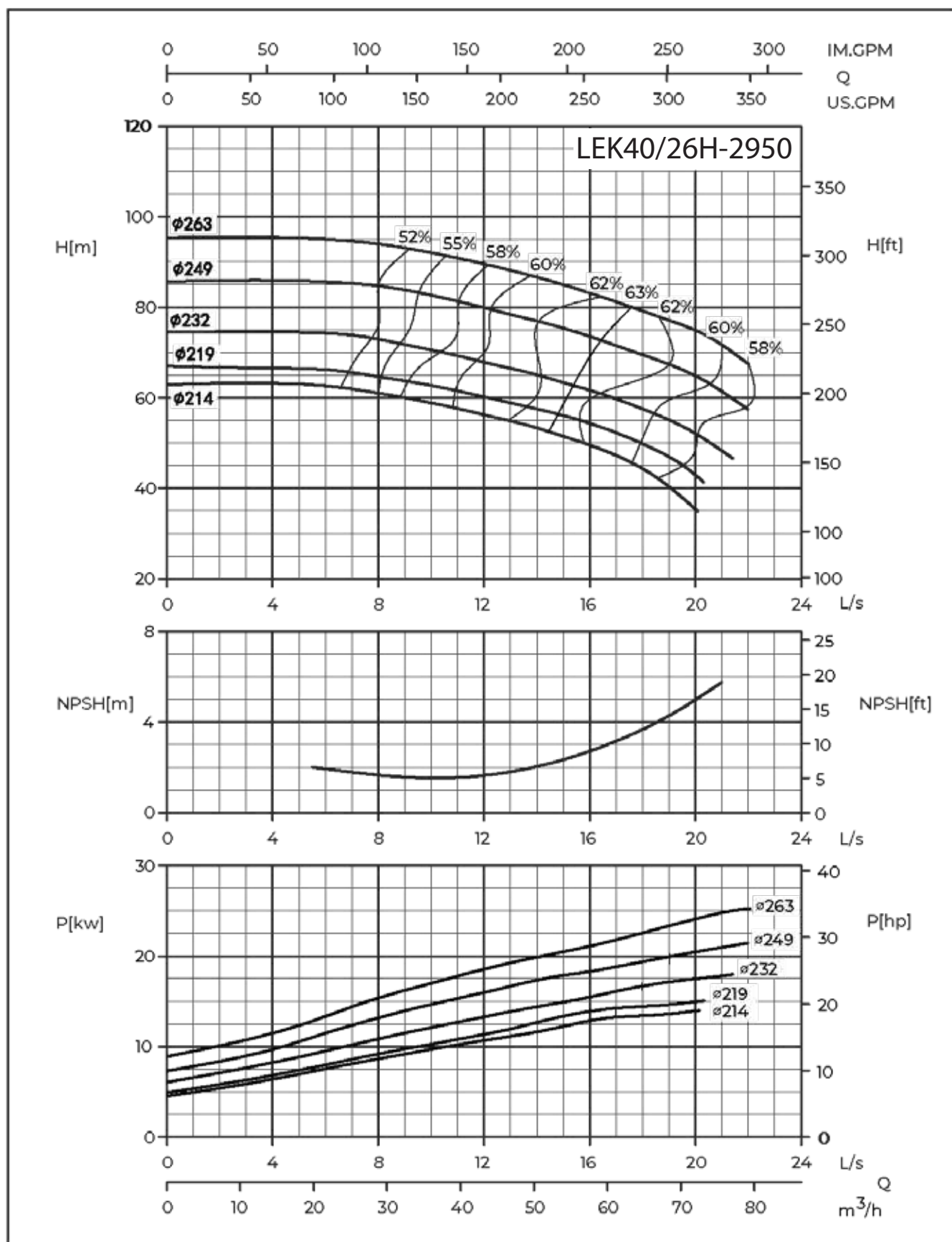

### END SUCTION PUMP PERFORMANCE CURVE LEK SERIES

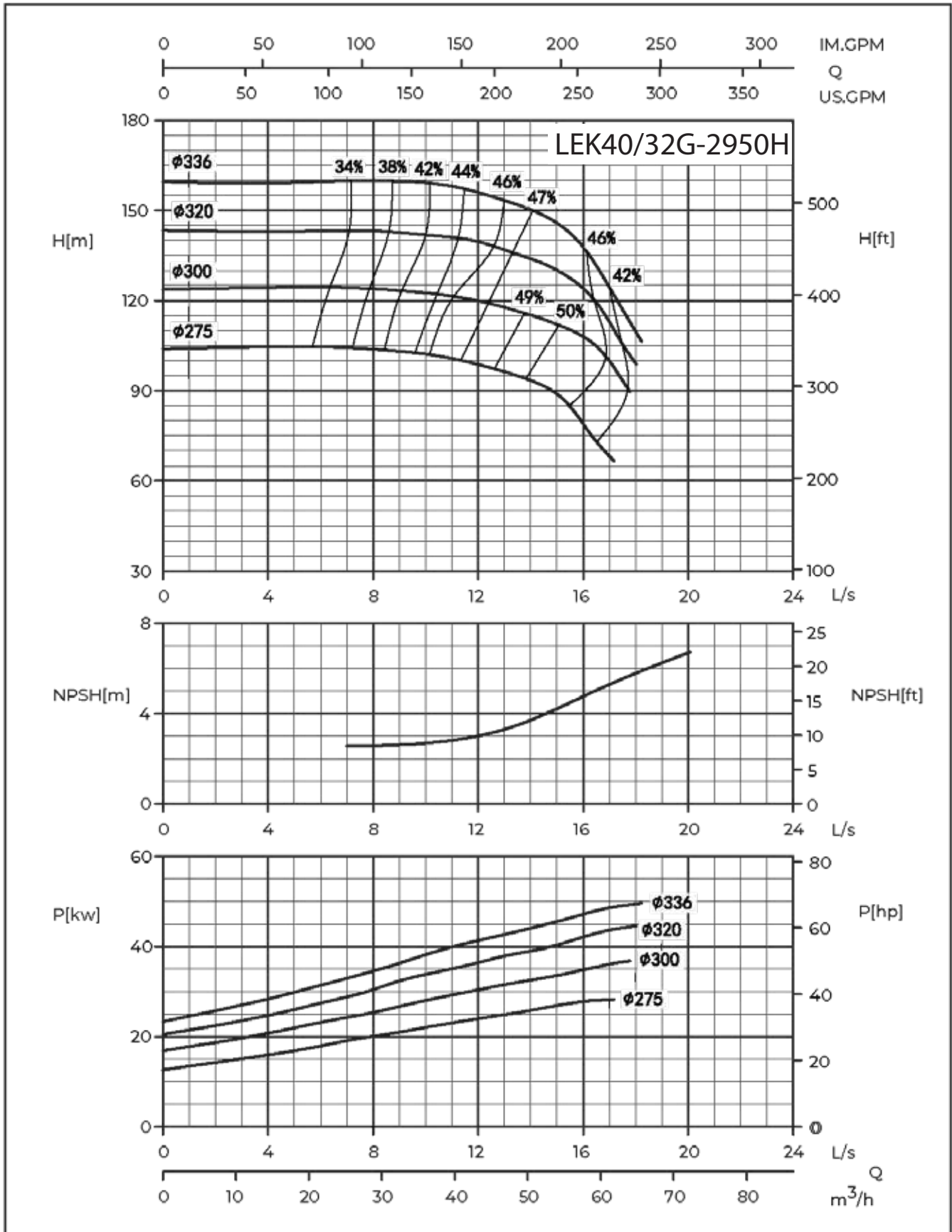

## END SUCTION PUMP PERFORMANCE CURVE LEK SERIES

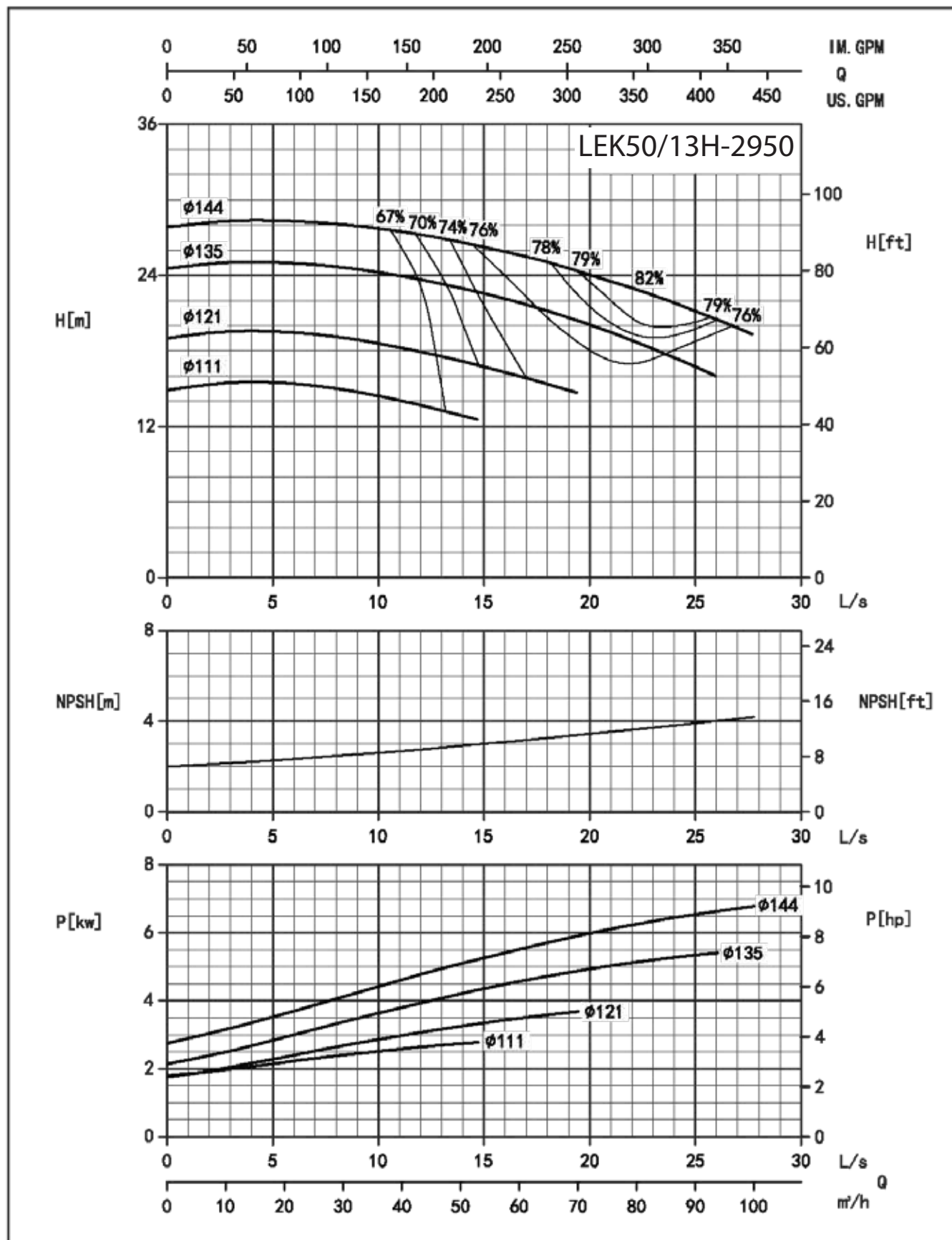

**END SUCTION PUMP PERFORMANCE CURVE  
LEK SERIES**

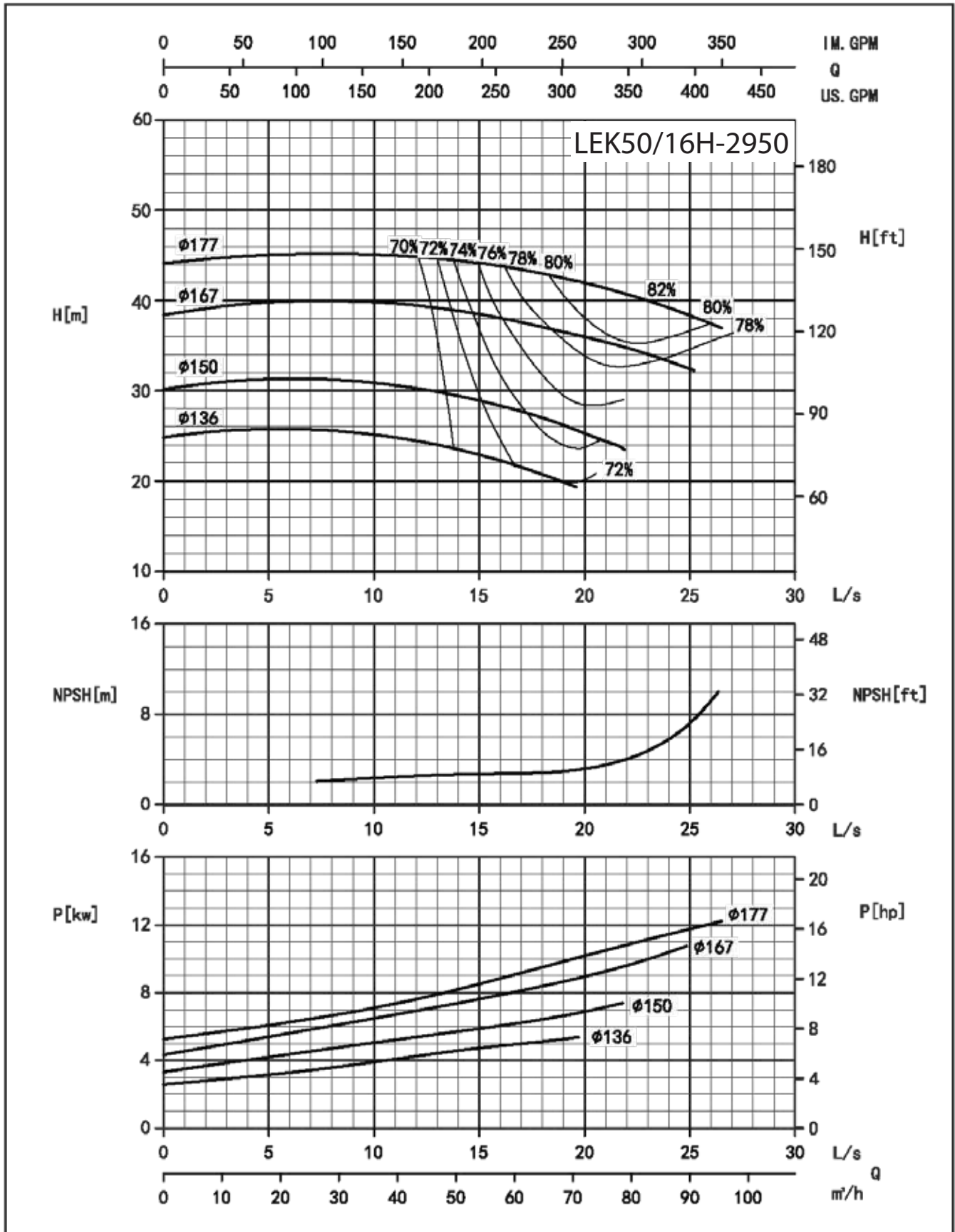

### END SUCTION PUMP PERFORMANCE CURVE LEK SERIES

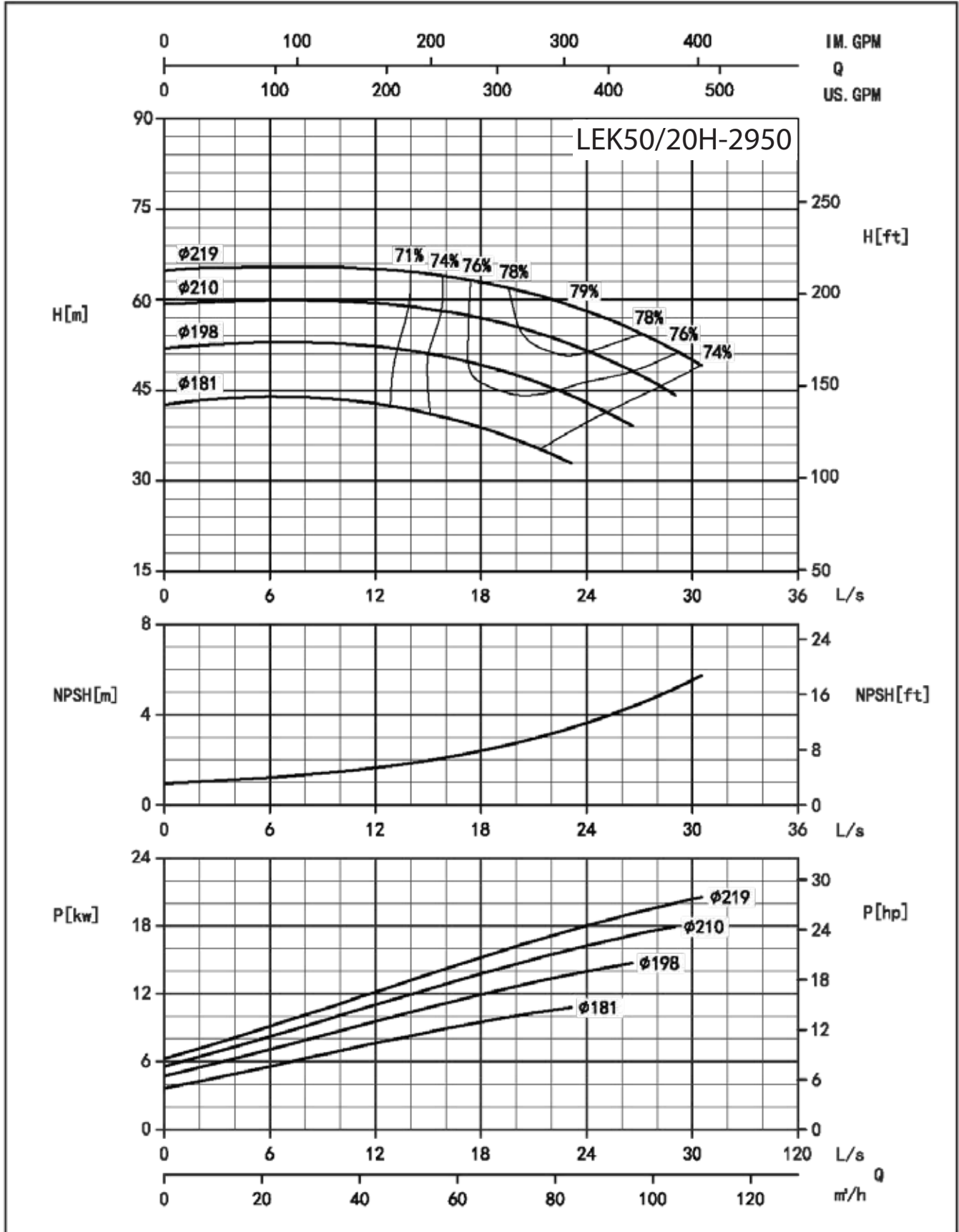

## END SUCTION PUMP PERFORMANCE CURVE LEK SERIES

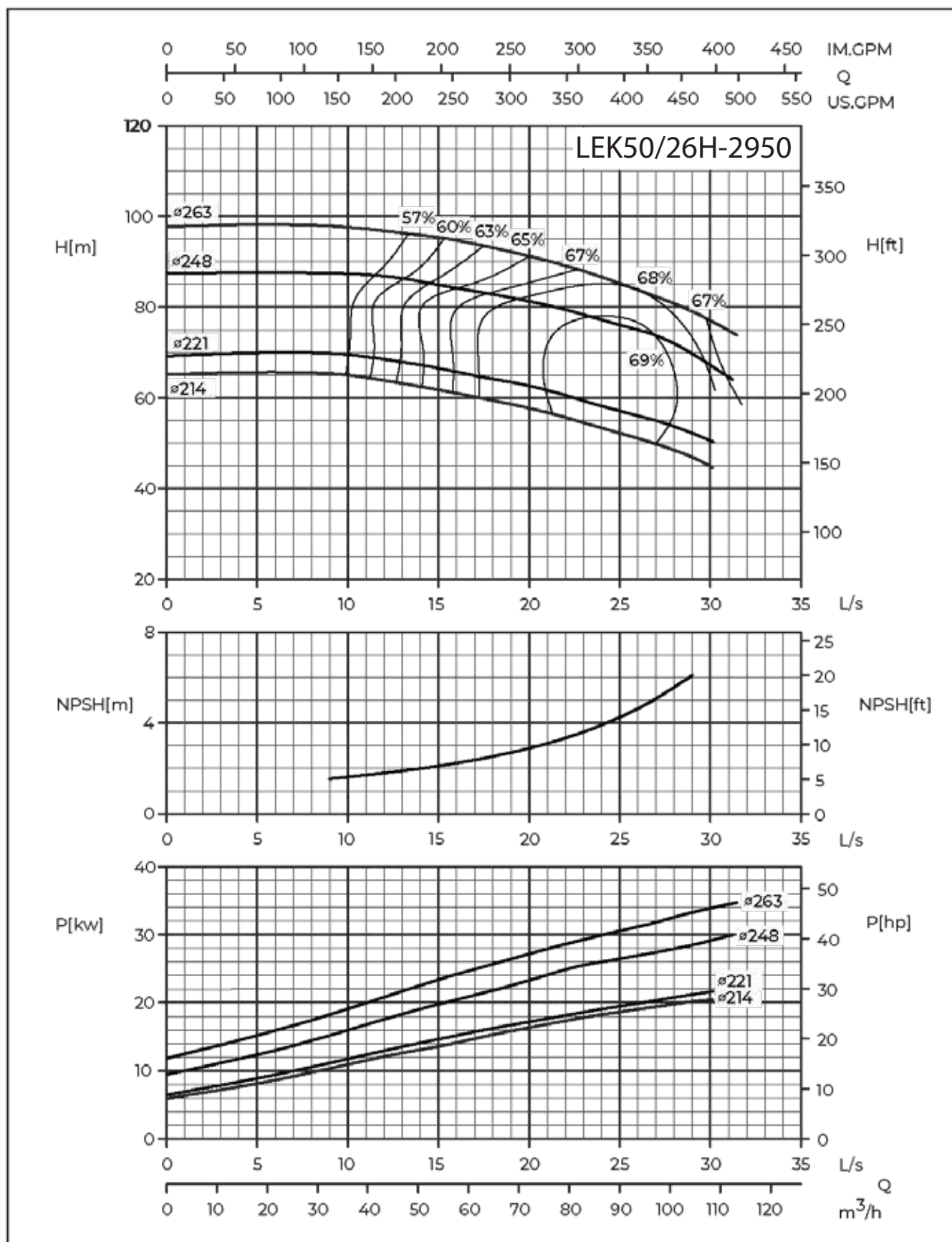

### END SUCTION PUMP PERFORMANCE CURVE LEK SERIES

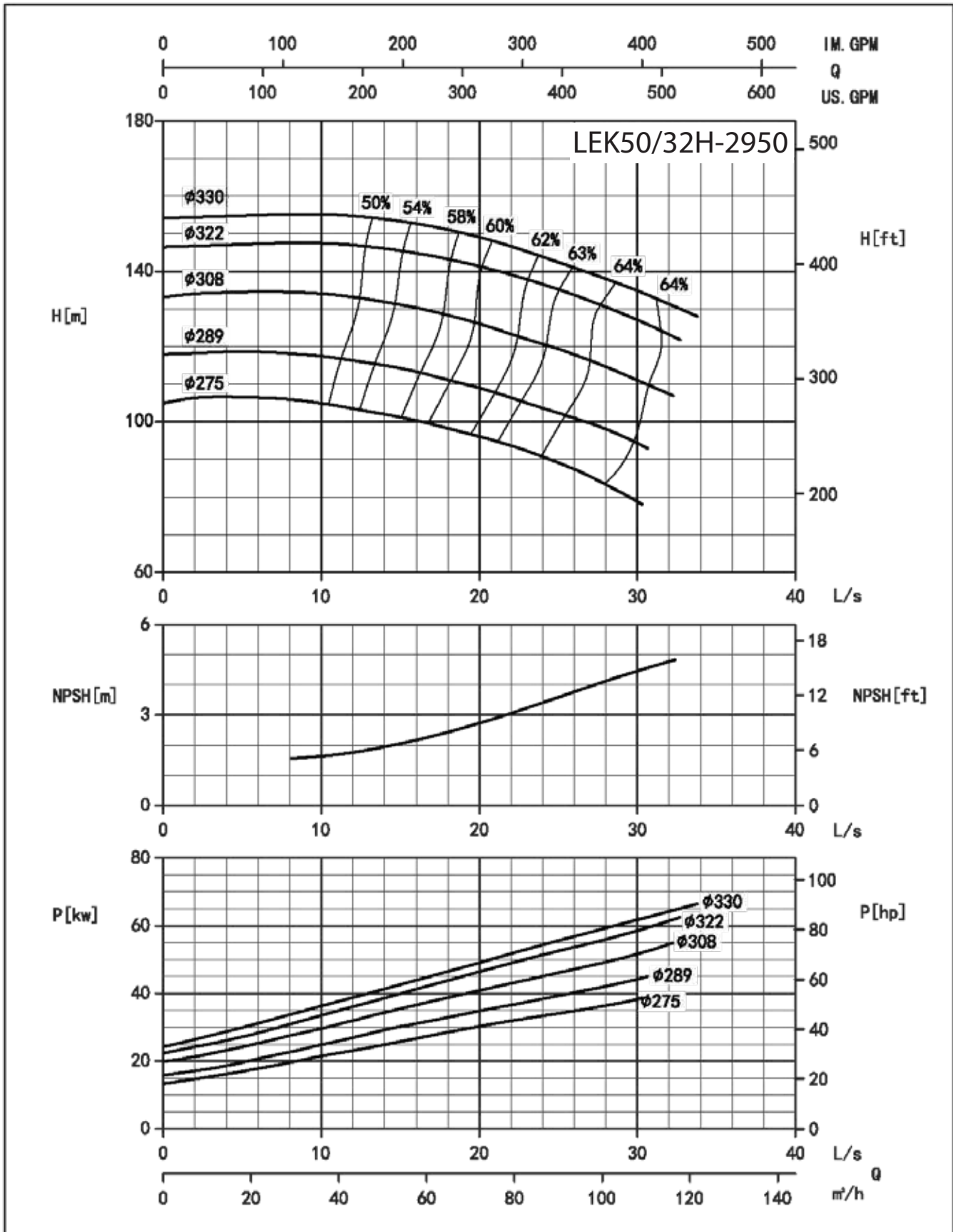

**END SUCTION PUMP PERFORMANCE CURVE  
LEK SERIES**

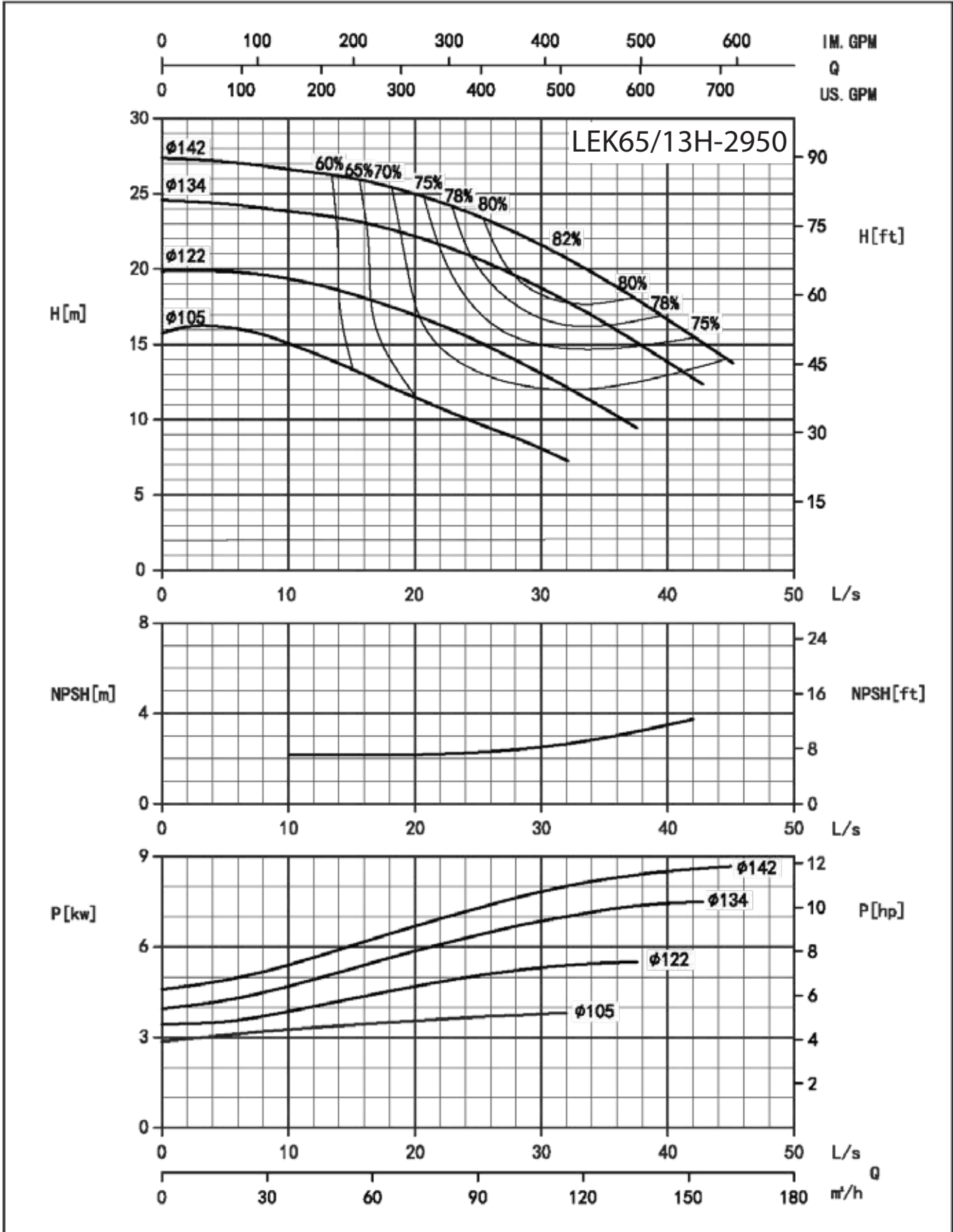

### END SUCTION PUMP PERFORMANCE CURVE LEK SERIES

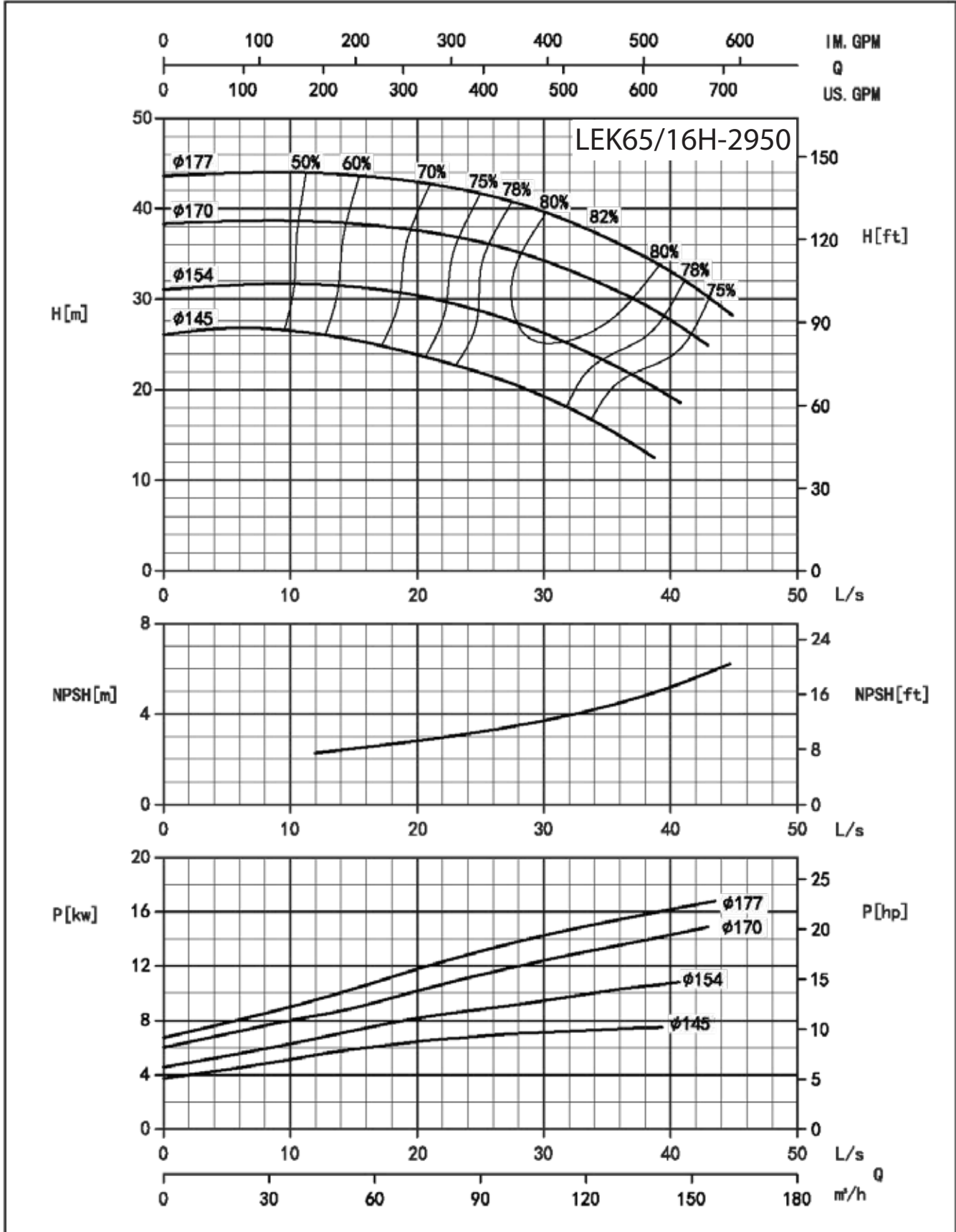

## END SUCTION PUMP PERFORMANCE CURVE LEK SERIES

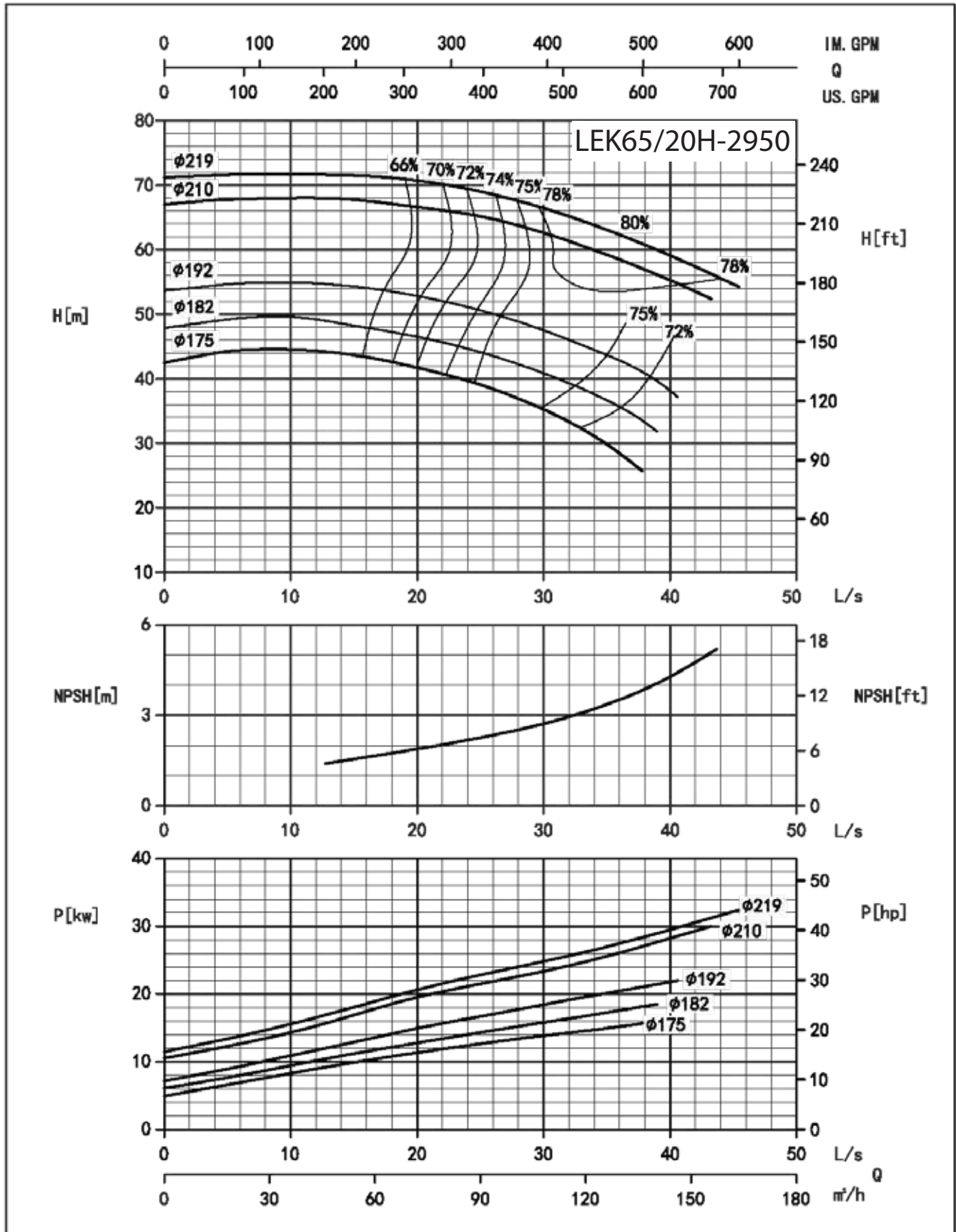

### END SUCTION PUMP PERFORMANCE CURVE LEK SERIES

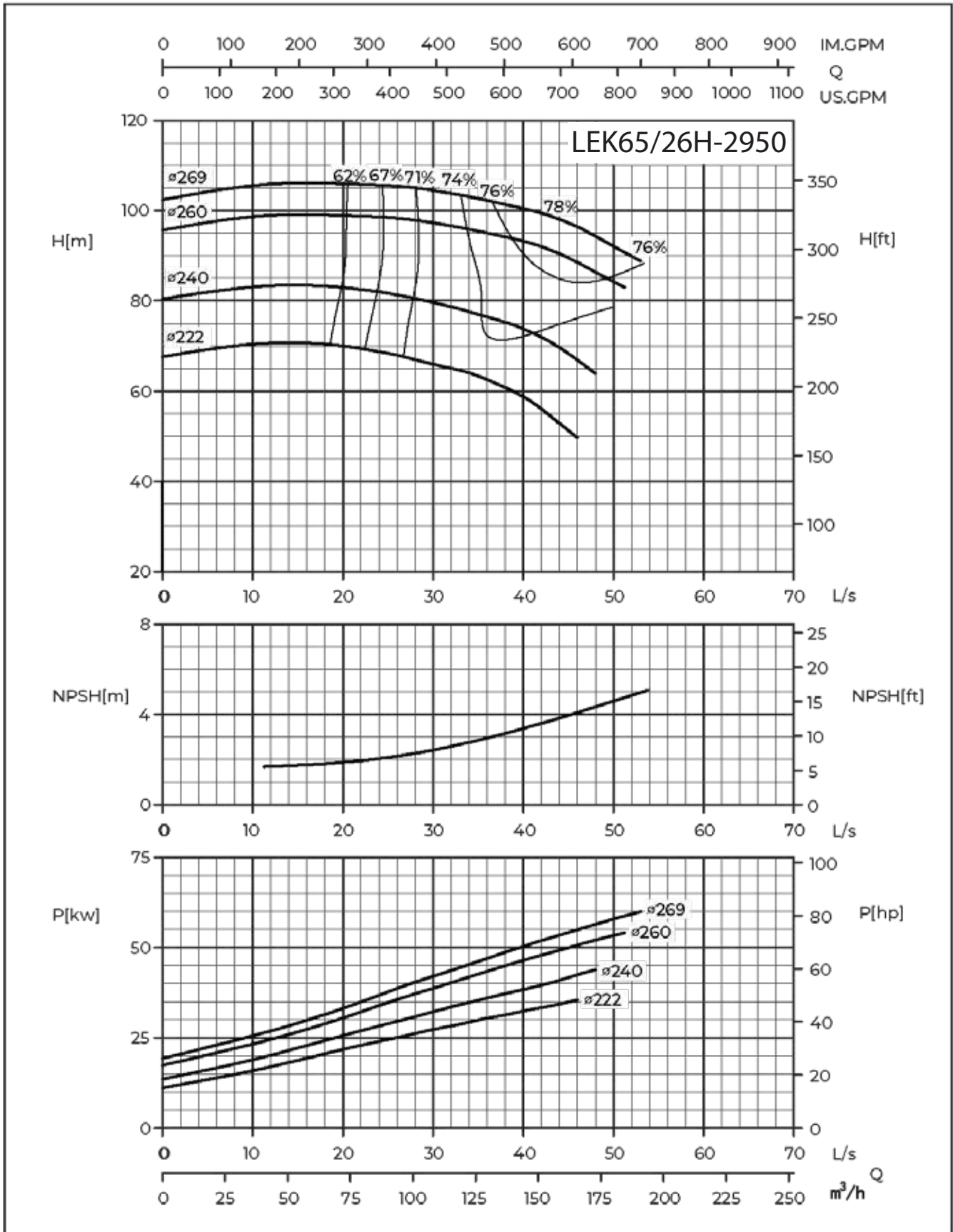

**END SUCTION PUMP PERFORMANCE CURVE  
LEK SERIES**

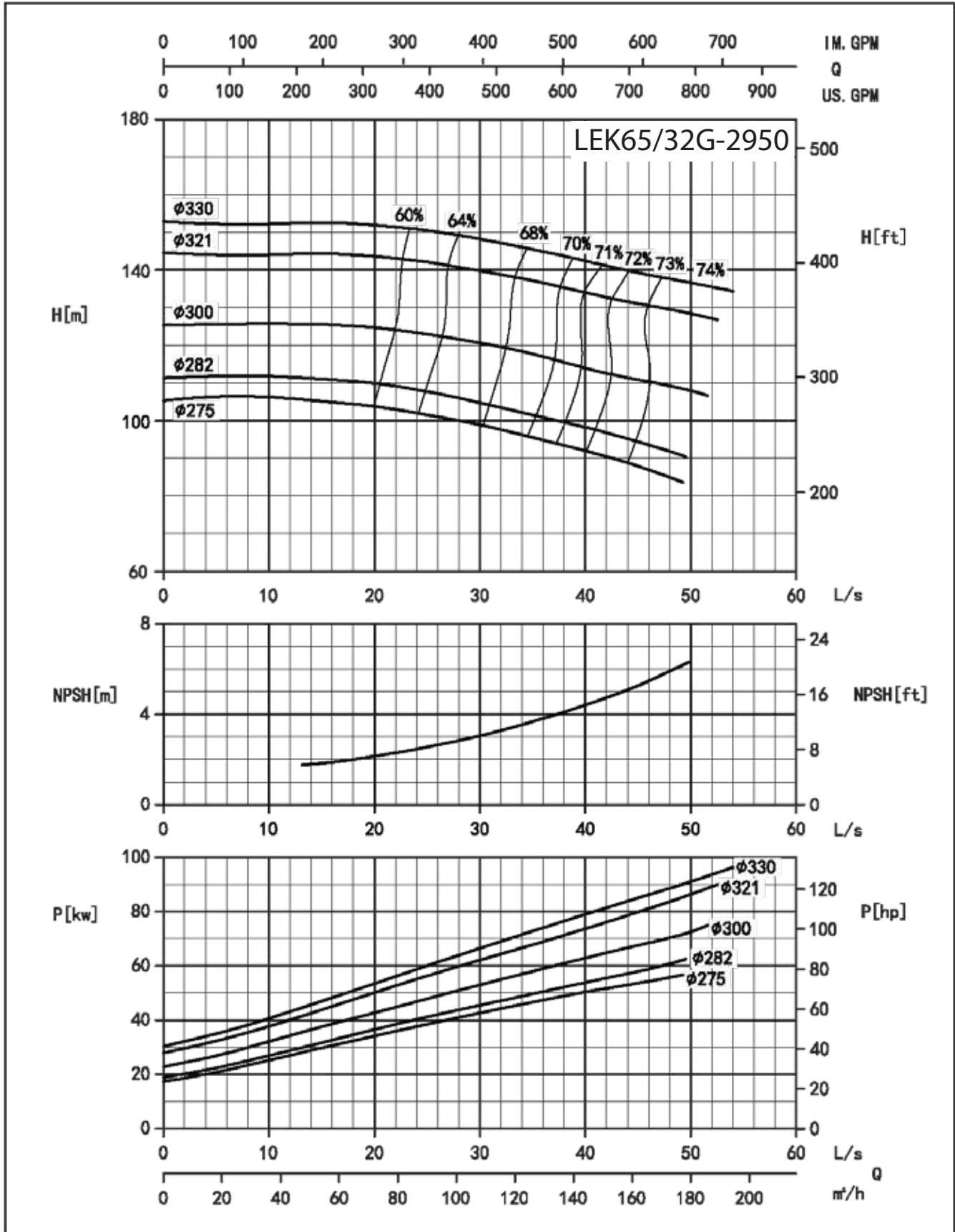

# LEK

## End Suction Pump

### END SUCTION PUMP PERFORMANCE CURVE LEK SERIES

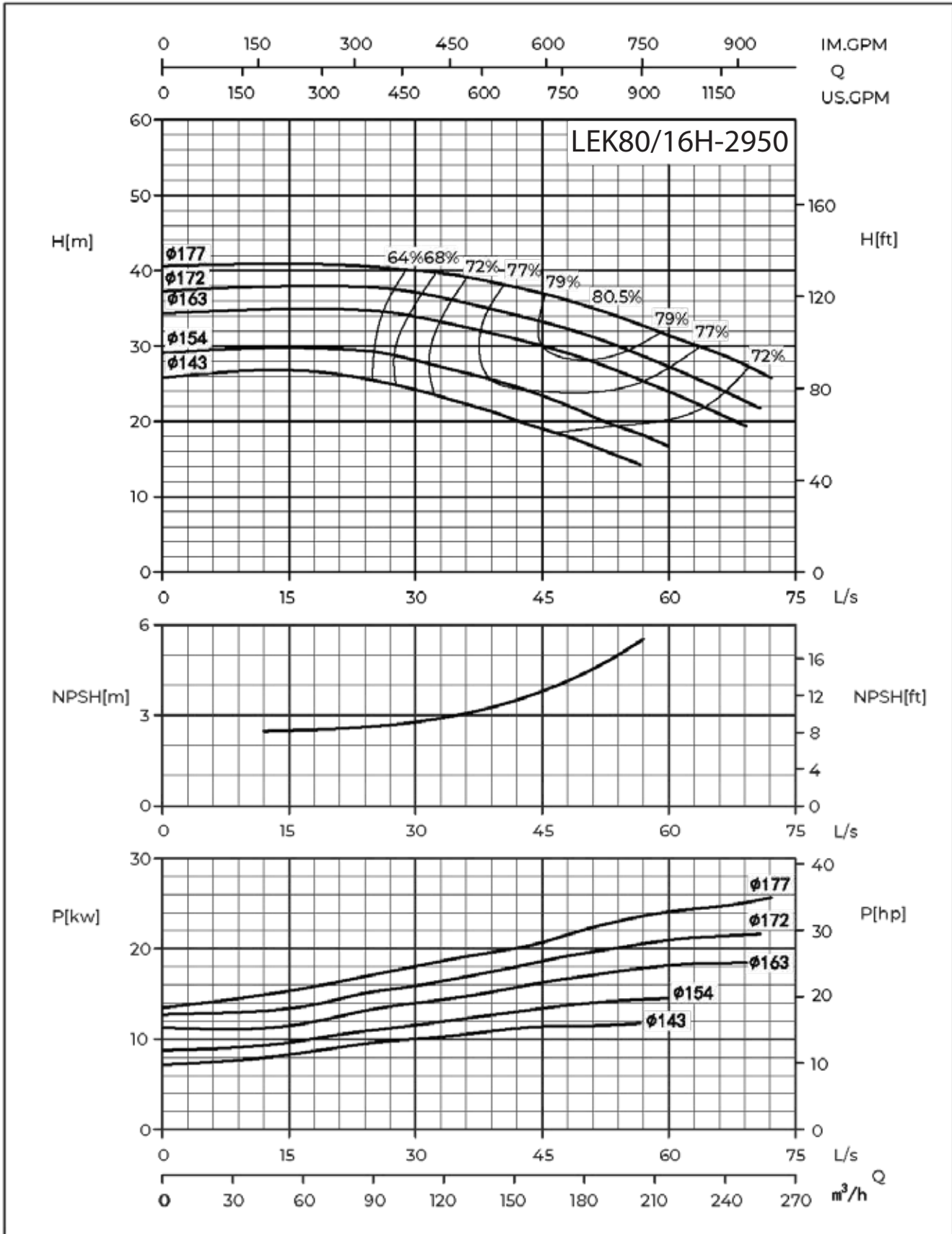

## END SUCTION PUMP PERFORMANCE CURVE LEK SERIES

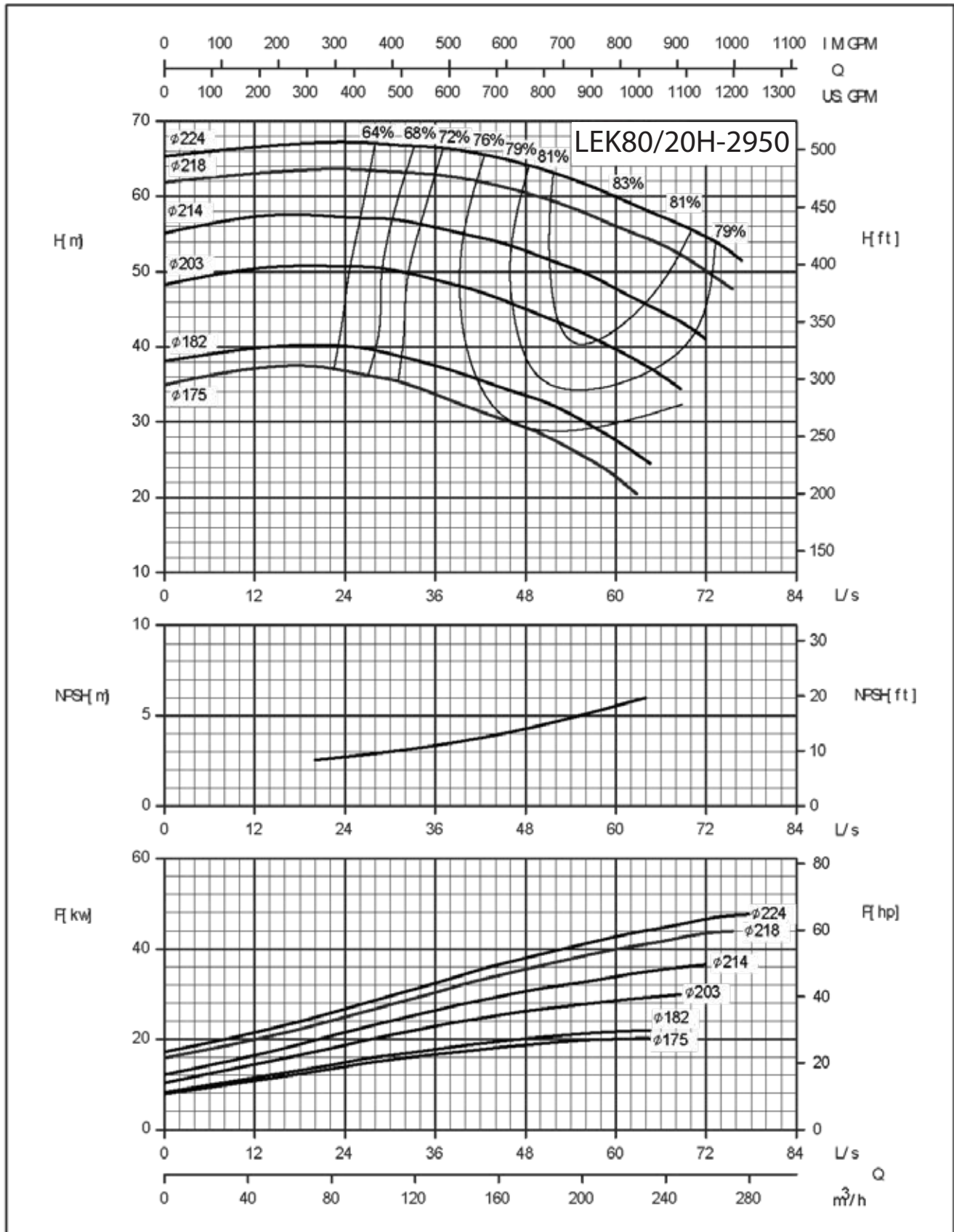

### END SUCTION PUMP PERFORMANCE CURVE LEK SERIES

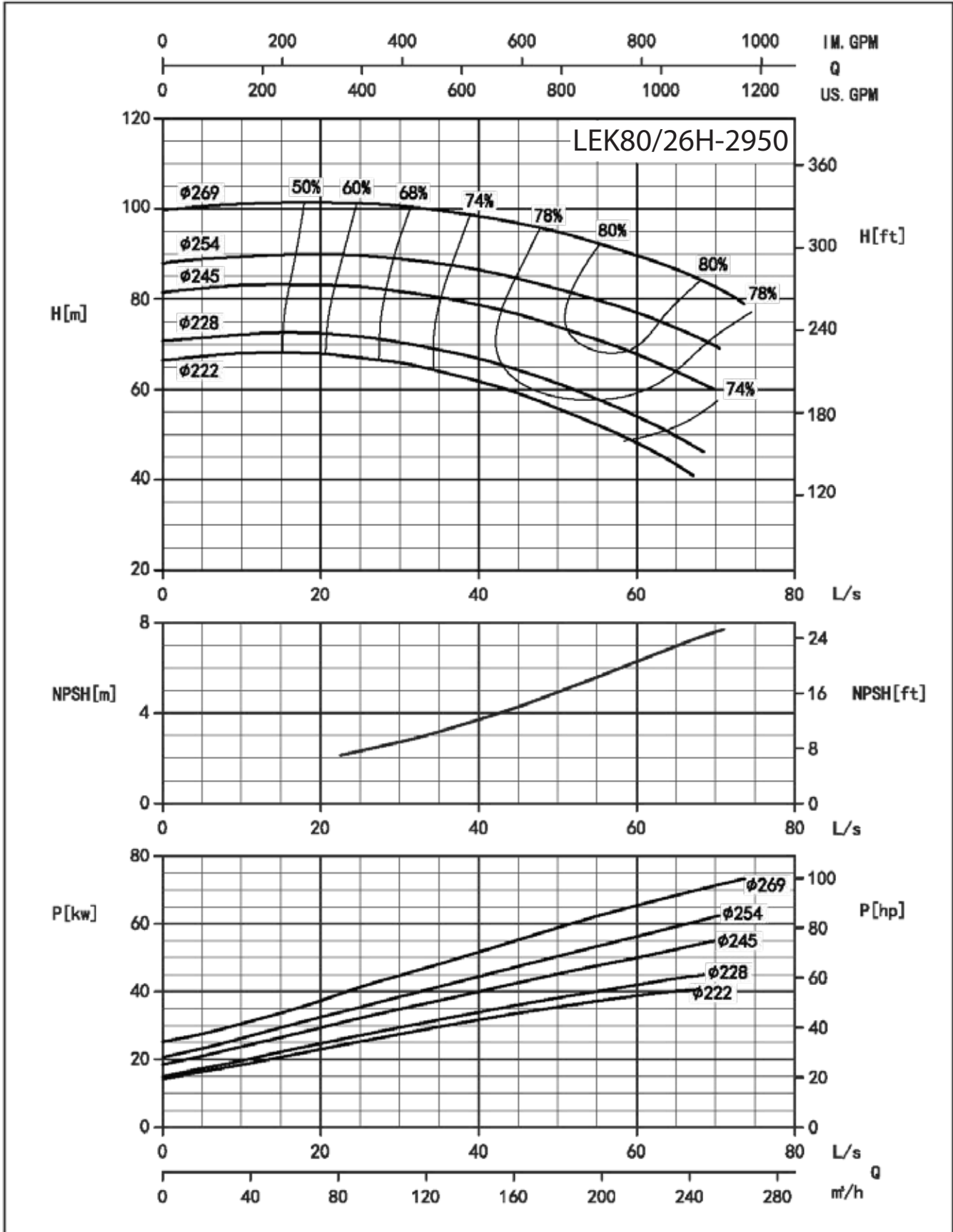

## END SUCTION PUMP PERFORMANCE CURVE LEK SERIES

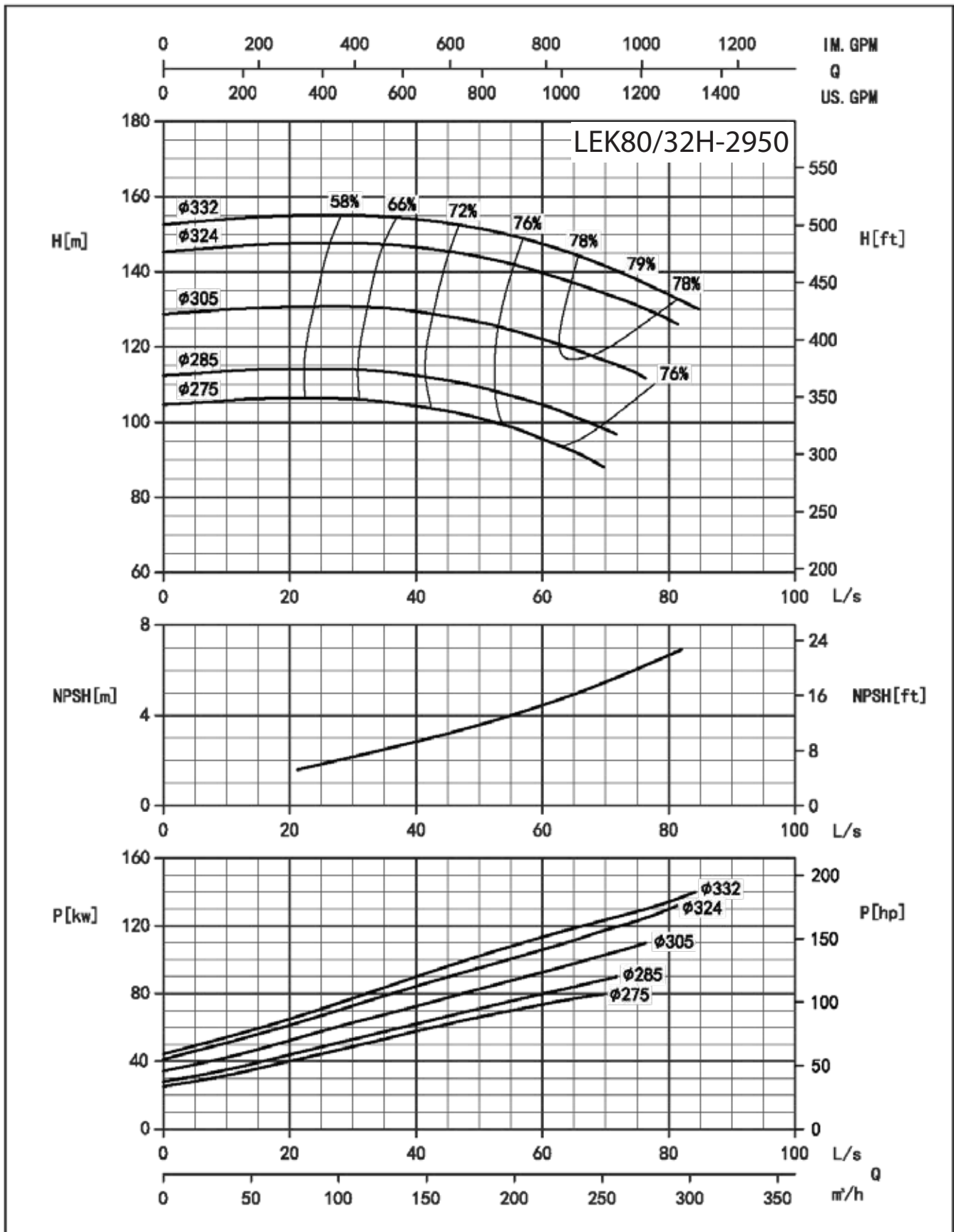

### END SUCTION PUMP PERFORMANCE CURVE LEK SERIES

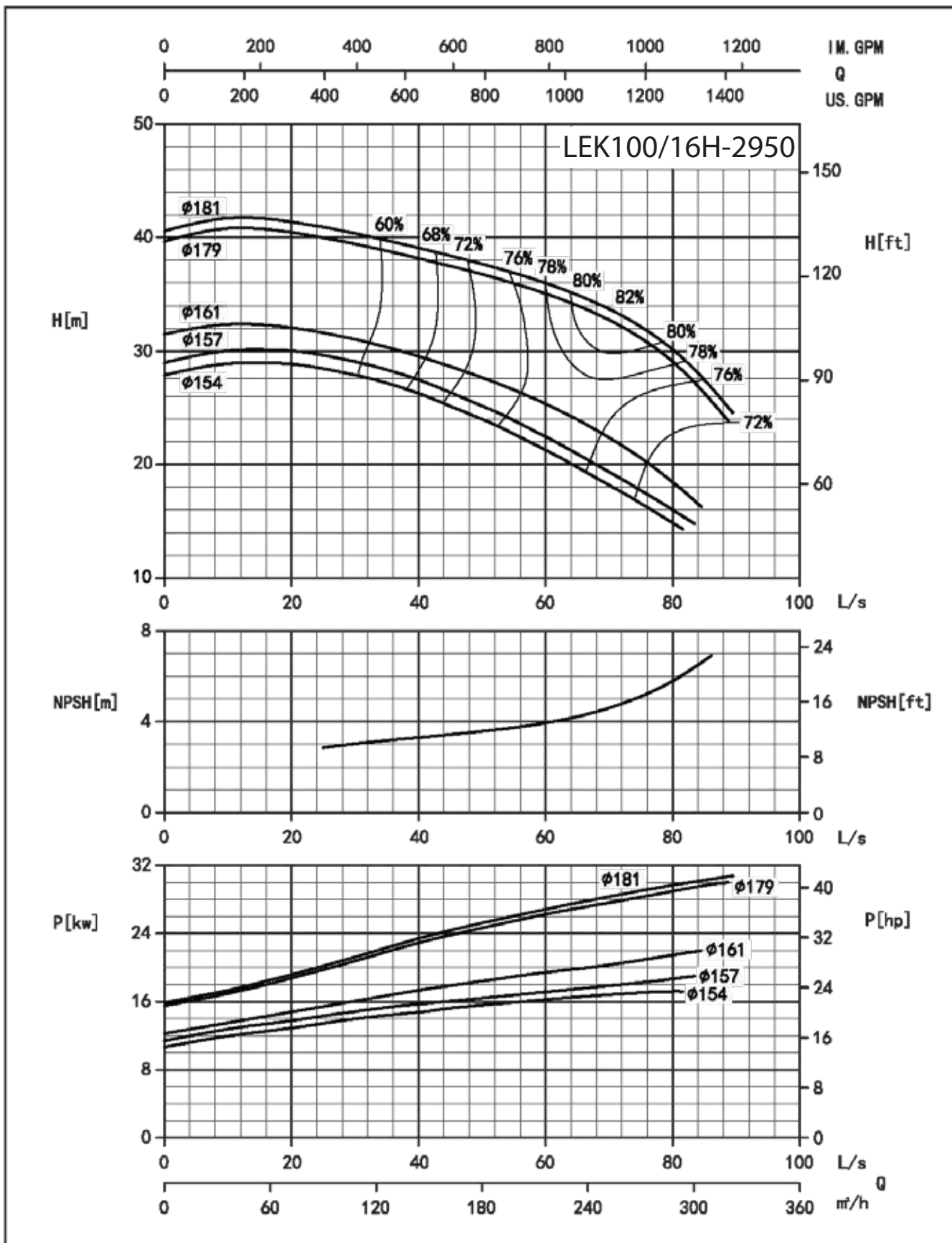

## END SUCTION PUMP PERFORMANCE CURVE LEK SERIES

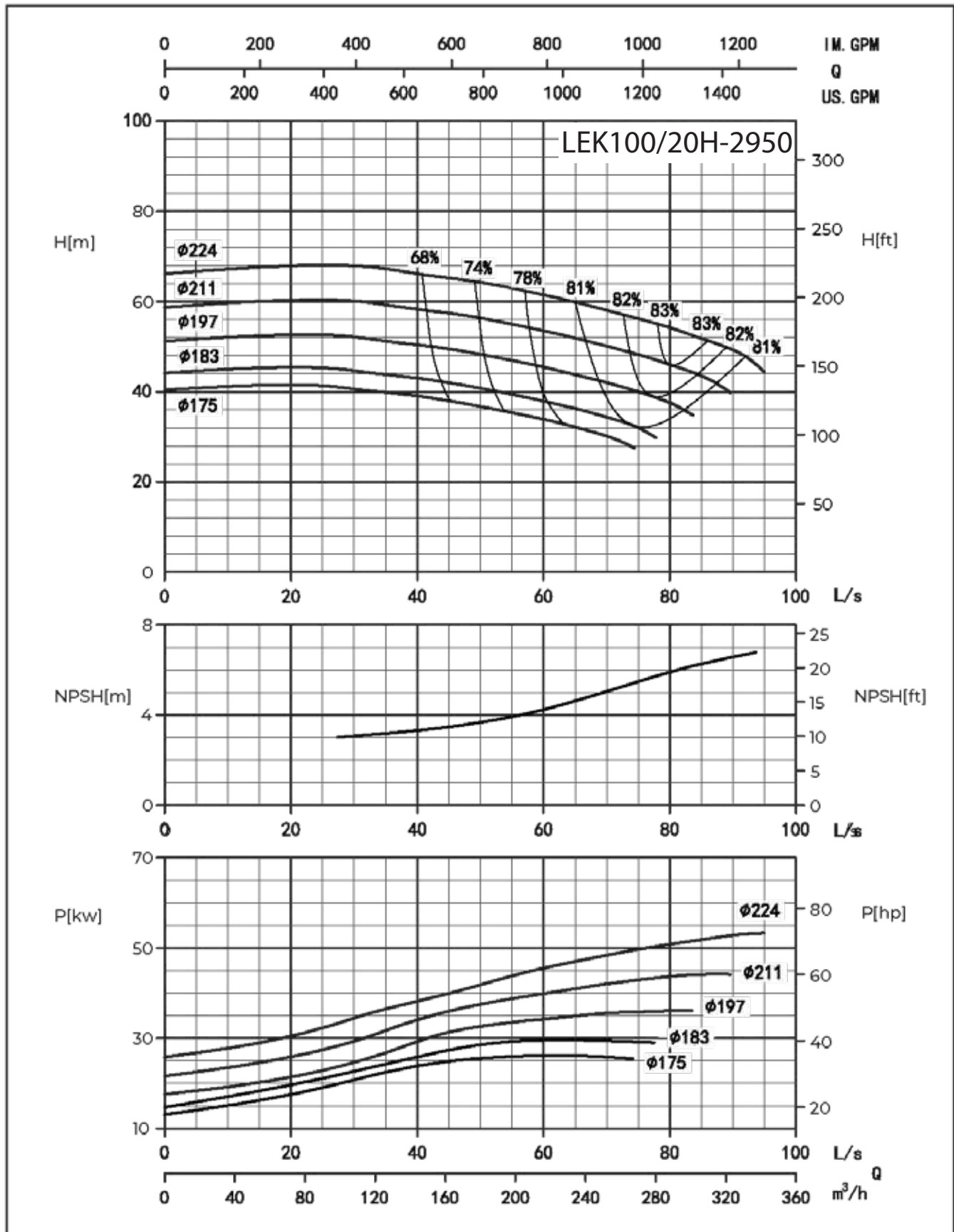

### END SUCTION PUMP PERFORMANCE CURVE LEK SERIES

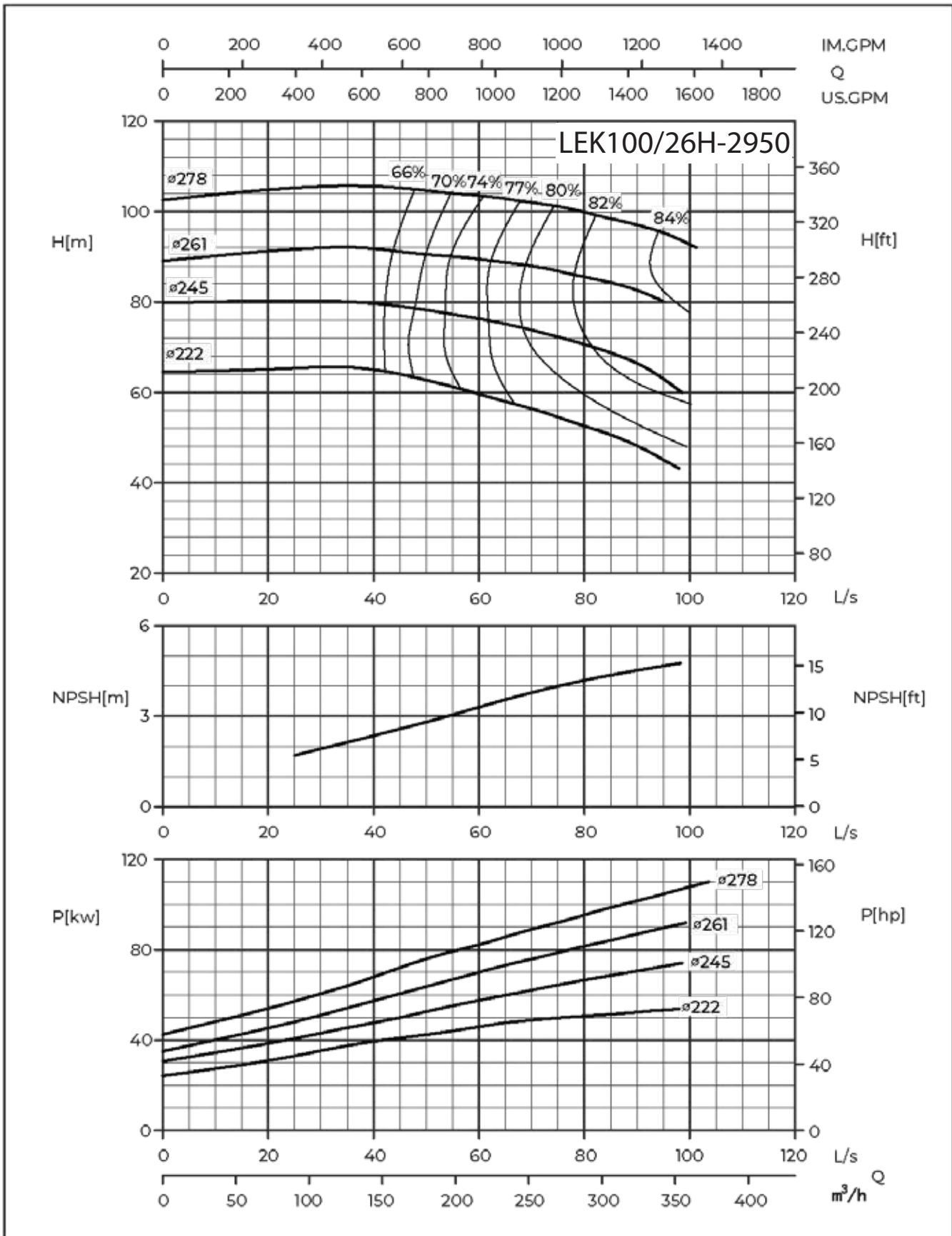

## END SUCTION PUMP PERFORMANCE CURVE LEK SERIES

