

KBZE INTELLIGENT SUBMERSIBLE DRAINAGE PUMP

The body of motor and pump is made of rigid cast iron for long-lasting durability. Greatly increased maximum submersion depth due to mechanical seal resistant to high pressure. Semi-open impeller made of high chrome alloy match with wear plate (ductile iron) achieves superior durability. Effective motor cooling due to discharge channel cast as part of the motor housing. Space saved economically by a top outlet. The pump can operate automatically with built-in intelligent control system, thus achieve low total energy costs.

Main advantages

- Protect against reverse phase, ensuring correct impeller rotation;
- Protect against open phase or impeller jam, thus prevent accidental damage;
- Automatically stop the pump in event of overload, abnormal voltage and recovery 5min later;
- The pump stops working at high temperature, and will automatically restart after cooling to the specified temperature;
- The water sensor's height is adjustable to control pump operation and stop;
- The pump stops working within 60s when water level is below the probe, When the water level rises to contact the electric probe, pump starts operating again;
- Rapid assessment about the pump operation and malfunction history.



Specification

- Capacity: up to 105m³/h
- Head: up to 38 meters
- Power: 1.5kW (2HP) to 5.5 kW (7.5HP)
- Power supply: three phase 400V ± 10%, 50Hz
380V ± 10%, 60Hz
- Insulation class: F
- Protection class: IP68
- Cable length: 8m
- Water temperature: up to 40°C
- Max. water depth: 25m

Application

- Civil engineering
- Mines, quarries, coal ore & slurries
- Sewage treatment plants
- General pumping purposes

Special features on request

- Other voltages
- The length of cable is optional

Automatic control

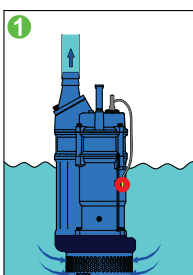

1 Pump continues to run while the electric probe remains submerged.

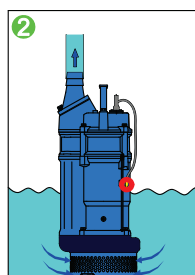

2 When the water surface falls below the electric probe, timer starts to count about one minute.

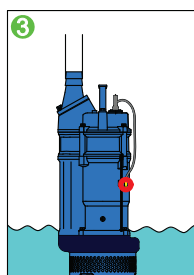

3 Pump stops in about one minute after the water level falls.

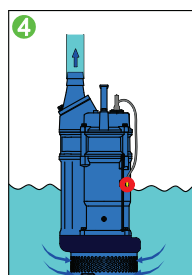

4 When the water level rises to contact the electric probe, pump starts operating again.

The process is repeated.

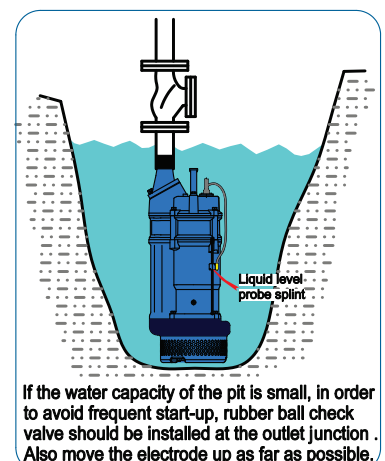

If the water capacity of the pit is small, in order to avoid frequent start-up, rubber ball check valve should be installed at the outlet junction. Also move the electrode up as far as possible.

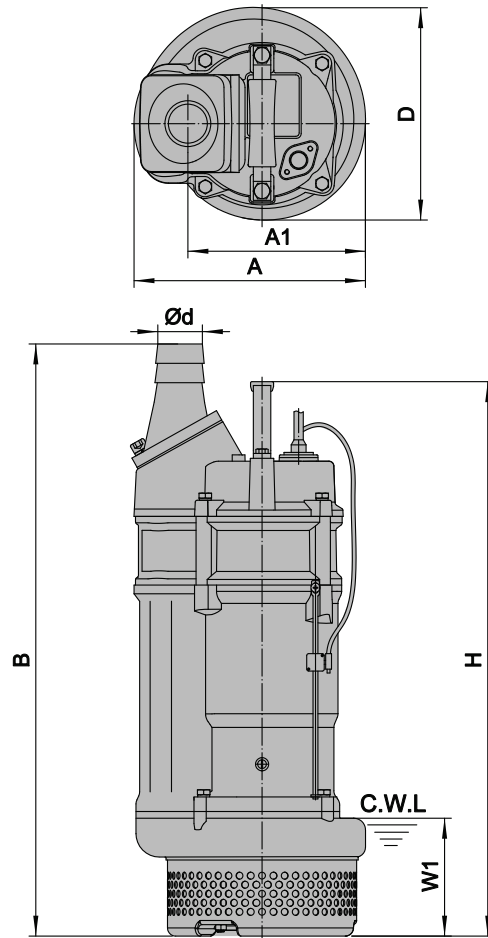
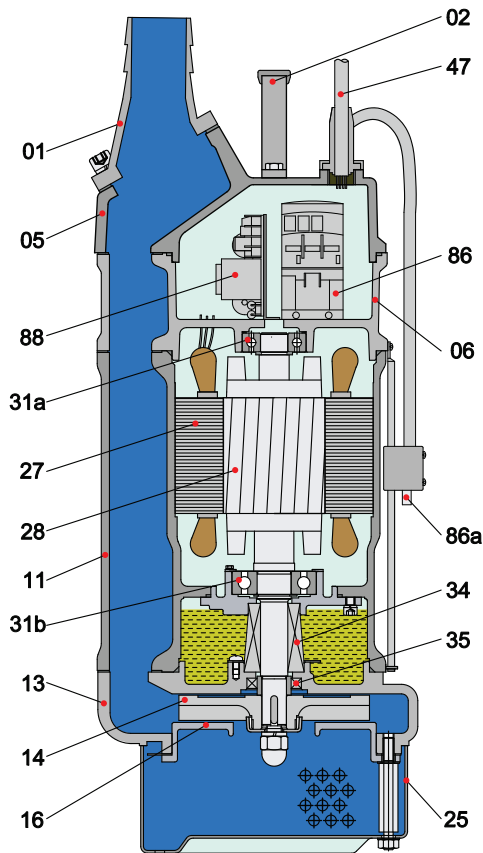

C.W.L:Continuous running water level

Material of construction

Item No.	Part name	Material	Item No.	Part name	Material
01	Hose coupling	Cast iron	28	Rotor	Shaft:AISI420SS
02	Handle	Rubber&steel	31a	Bearing	Ball bearing
05	Upper cover	Cast iron	31b	Bearing	Ball bearing
06	Upper support	Cast iron	34	Mechanical seal	Sic-Sic/Carbon-Sic (<2.2kW) Sic-Sic/Sic-Sic (>3.7kW)
11	Motor body	Cast iron	35	Oil seal	
13	Pump body	Cast iron	47	Cable	
14	Impeller	High chrome alloy	86	AC Contactor	
16	Inlet plate	Ductile iron	86a	Water level sensor	
25	Strainer	Steel	88	Controller block	
27	Stator				

Dimensions & weights

Model (50/60Hz)	d	A	A1	B	D	H	W1	N.W	G.W	Packing dimension mm
	mm	mm	mm	mm	mm	mm	mm	Kg	Kg	
KBZE21.5	50	235	190	613	216	582	120	41	45	680x265x275
KBZE31.5	80	235	190	620	216	582	120	41	45	680x265x275
KBZE22.2	50	235	190	613	216	582	120	44	48	680x265x275
KBZE32.2	80	235	190	620	216	582	120	44	48	680x265x275
KBZE23.7	50	283	223	703	252	707	150	71	76	790x320x305
KBZE33.7	80	283	223	703	252	707	150	71	76	790x320x305
KBZE43.7	100	283	223	728	252	707	150	72	77	790x320x305
KBZE35.5	80	329	240	755	300	668	150	85.5	92.5	845x355x375
KBZE45.5	100	329	240	780	300	668	150	86.5	93.5	845x355x375

KBZE INTELLIGENT SUBMERSIBLE DRAINAGE PUMP

Performance curves

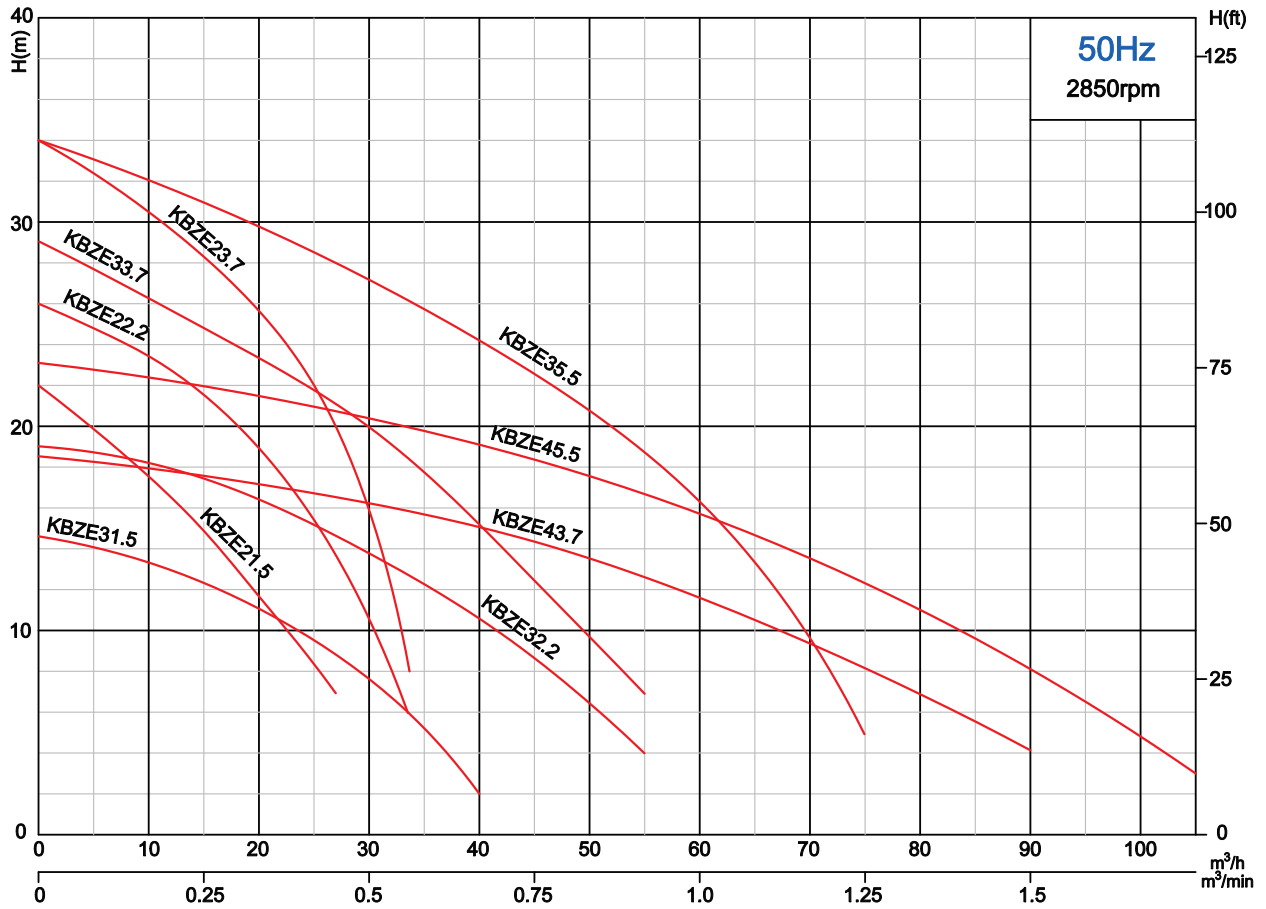

Performance table

Model (50Hz)	Outlet	Motor power		Rated current (400V)	Rated capacity		Rated head	Max capacity		Max Head	Impeller Passage
	mm	kW	HP	A	m³/h	m³/min	m	m³/h	m³/min	m	mm
KBZE21.5	50	1.5	2	3.5	15	0.25	15	27	0.45	22	8.5
KBZE31.5	80	1.5	2	3.5	30	0.50	8	40	0.67	14.5	8.5
KBZE22.2	50	2.2	3	5.0	18	0.30	20	33	0.55	26	8.5
KBZE32.2	80	2.2	3	5.0	36	0.60	11	55	0.92	19	8.5
KBZE23.7	50	3.7	5	7.7	12	0.20	30	33	0.55	34	8.5
KBZE33.7	80	3.7	5	7.7	30	0.50	20	55	0.92	29	8.5
KBZE43.7	100	3.7	5	7.7	60	1.0	11.5	90	1.50	18.5	8.5
KBZE35.5	80	5.5	7.5	11.4	36	0.60	25	75	1.25	34	8.5
KBZE45.5	100	5.5	7.5	11.4	60	1.0	16	105	1.75	23	8.5

Performance curves

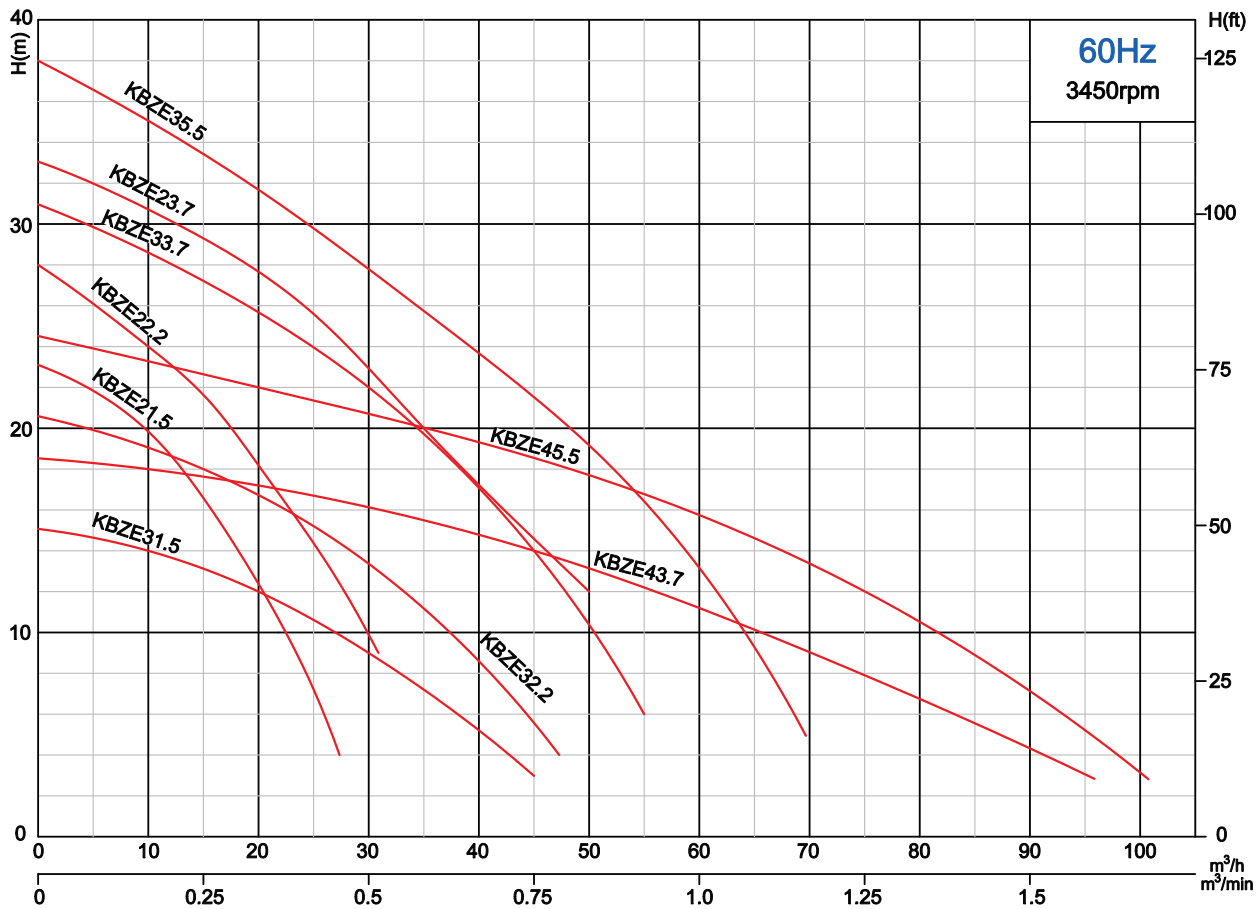

Performance table

Model (60Hz)	Outlet	Motor power		Rated current (380V)	Rated capacity		Rated head	Max capacity		Max Head	Impeller Passage
	mm	kW	HP	A	m³/h	m³/min	m	m³/h	m³/min	m	mm
KBZE21.5	50	1.5	2	3.5	15	0.25	16.5	27	0.45	23	8.5
KBZE31.5	80	1.5	2	3.5	30	0.50	9	45	0.75	15	8.5
KBZE22.2	50	2.2	3	5.1	18	0.30	20	31	0.52	28	8.5
KBZE32.2	80	2.2	3	5.1	30	0.60	13	47	0.78	20.5	8.5
KBZE23.7	50	3.7	5	8.0	12	0.20	30	50	0.83	33	8.5
KBZE33.7	80	3.7	5	8.0	30	0.50	22	55	0.92	31	8.5
KBZE43.7	100	3.7	5	8.0	60	1.0	11.5	96	1.60	18.5	8.5
KBZE35.5	80	5.5	7.5	11.6	36	0.60	25	69	1.15	38	8.5
KBZE45.5	100	5.5	7.5	11.6	60	1.0	16	102	1.70	24.4	8.5