



Application

- Wastewater drainage in factories, construction sites and commercial facilities
- Drainage system in municipal sewage treatment plants
- Drainage station in residential quarters
- Municipal projects
- Methane pools and field irrigation in countryside

Pump

- Max. immersion depth: 10 m
- 0.25-4kw. Standard PN6 pump body with hose coupling
- 5.5-7.5kw. Standard PN6 pump body with hose coupling, optional PN10 pump body, without hose coupling
- 11-22kW. Standard PN10 pump body, without hose coupling, optional PN6 pump body with hose coupling
- Can be equipped with hose connection can choose flange connection
- Cable Length: 10m (under 30kW), 8m (30-45kW)
- Max. liquid temperature: up to +40°C
- Liquid PH value: 4 - 10
- Max.liquid density: 1.3x10³ kg/m³
- Allowed by the particle diameter: 20 - 80 mm
- Single phase optional

Motor

- Copper winding
- Insulation class: F
- Enclosures class: IP68
- Motor protection: 0.25 - 4kW(5.5kW and above need control cabinet)
- 0.25-4kW: Star connection; 5.5-37kW: Delta connection; 45kW: Star-triangle connection

Identification Codes

65 WQ D 15-10-1.1(M)(A)/(4)

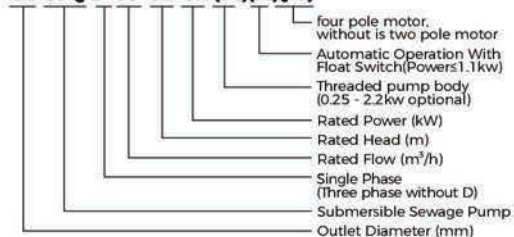

Material Table

No.	Part	Material	No.	Part	Material
01	Cable		12	Bearing	
02	Handle	AISI304	13	Oil Chamber	HT200
03	Top Cover	HT200	14	Mechanical Seal	
04	O-Ring	NBR	15	Pressing	AISI304
05	End Cover	HT200	16	O-Ring	NBR
06	O-Ring	NBR	17	Cylinder Head	HT200
07	Wave Spring Washer	65Mn	18	Oil Seal	
08	Bearing		19	Impeller	HT200
09	Rotor		20	Pump Body	HT200
10	Stator		21	Base	HT200
11	Motor Casing	HT200			

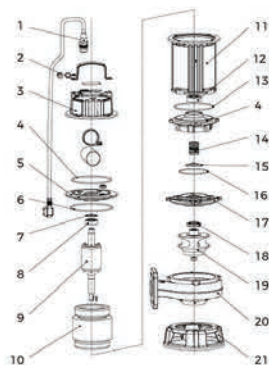

0.25 - 4 kW

Material Table

No.	Part	Material
01	Pedestal	HT200
02	Pump body	HT200
03	Air vent valve	
04	Washer	AISI304
05	Impeller	HT200
06	Casket seal	NBR
07	Cylinder Head	HT200
08	Mechanical seals	
09	Oil chamber	HT200
10	Ball bearing	
11	Cable assembly	
12	Rings	
13	Top cover	HT200
14	End cover	HT200

No.	Part	Material
15	Winding	
16	Mechine barrel	HT200
17	Ball bearing	
18	Motor	

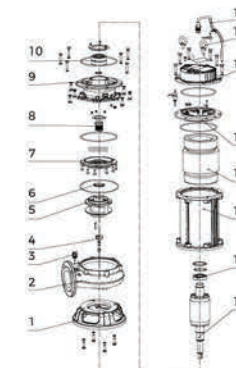

5.5 - 7.5 kW

No.	Part	Material
01	Pump base	HT200
02	Pump body	HT200/HT250/QT400
03	Impeller ring	45
04	Impeller	HT200/HT250/QT400
05	O-ring	NBR
06	Mechanical seal	Silicon/Carbon
07	Pump cover	HT200
08	O-ring	NBR
09	Mechanical seal	Silicon/Carbon
10	Oil chamber	HT200
11	O-ring	NBR
12	Float switch (optional)	AISI304
13	Oil-water probe (optional)	AISI304
14	Motor base	HT200
15	Handle components	Q235
16	Cable assembly	YCW
17	Cable clamp	HT200

No.	Part	Material
18	Signal line (optional)	YCW
19	Nameplate	AISI304
20	Top cover	HT200
21	O-ring	NBR
22	Water leakage protection(optional)	
23	Wiring base	
24	Upper cover	HT200
25	O-ring	NBR
26	Wave spring	65Mn
27	Ball bearing	
28	Rotor	
29	Bearing	
30	Snap ring	65Mn
31	Temperature sensor(optional)	
32	Stator	

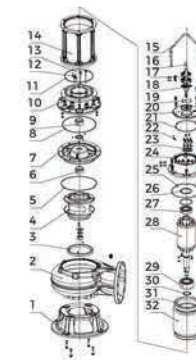

11 - 45 kW

Hydraulic Performance Curves

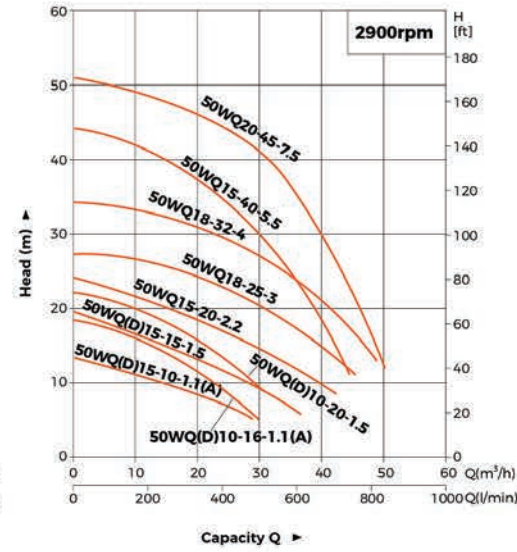
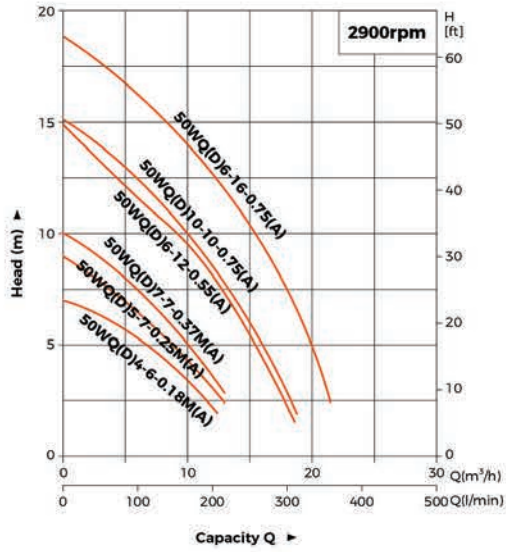

Hydraulic Performance Curves

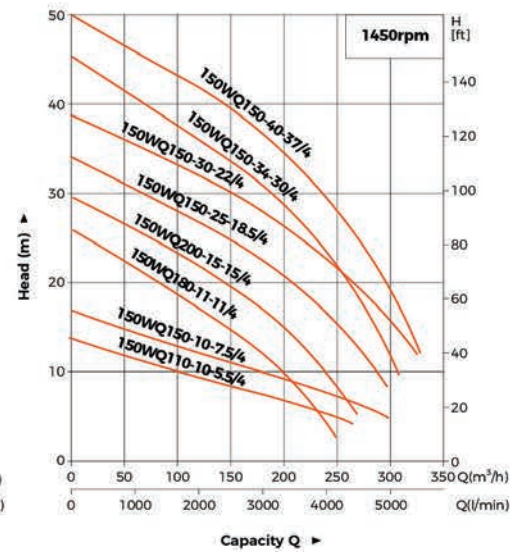
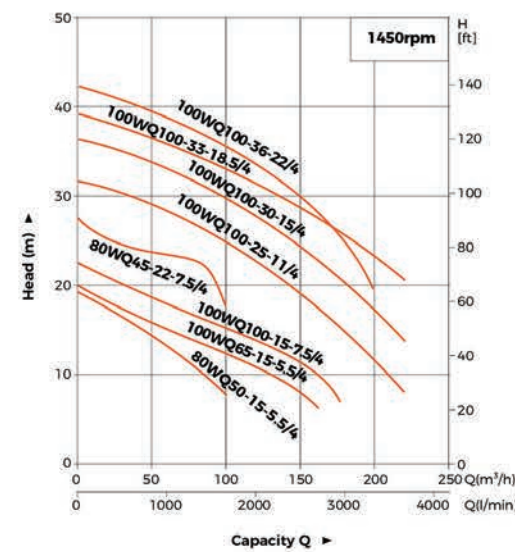
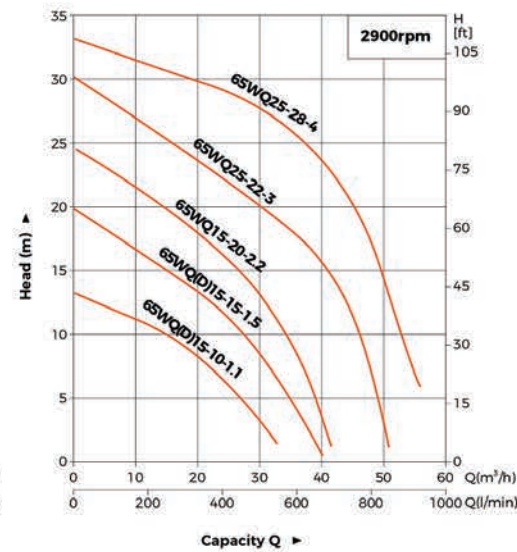
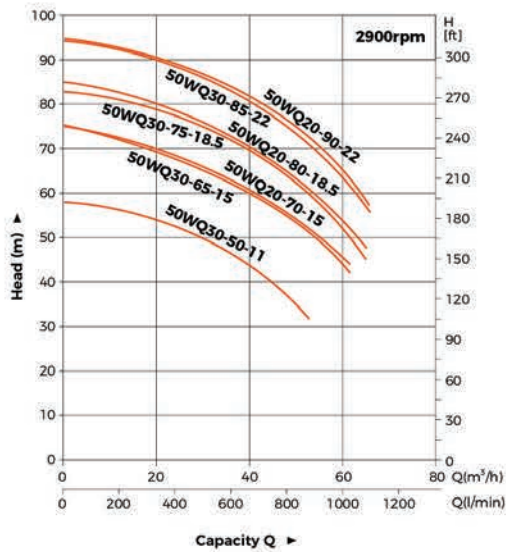
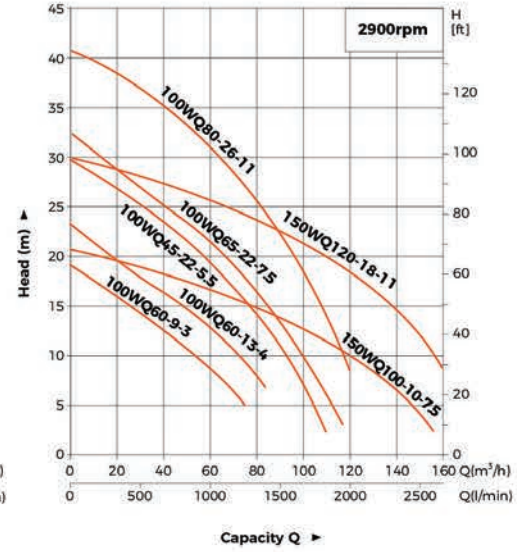
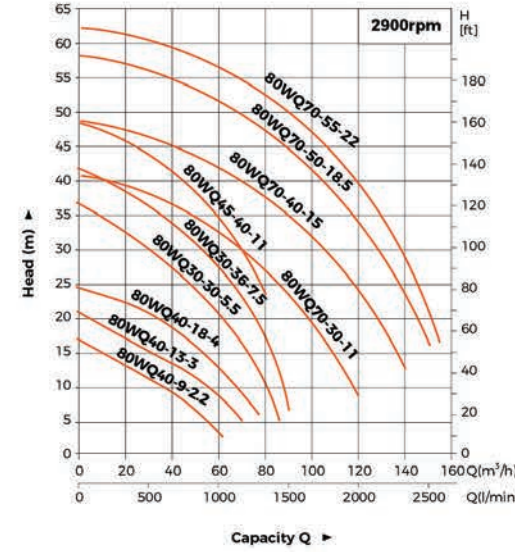

Hydraulic Performance Curves

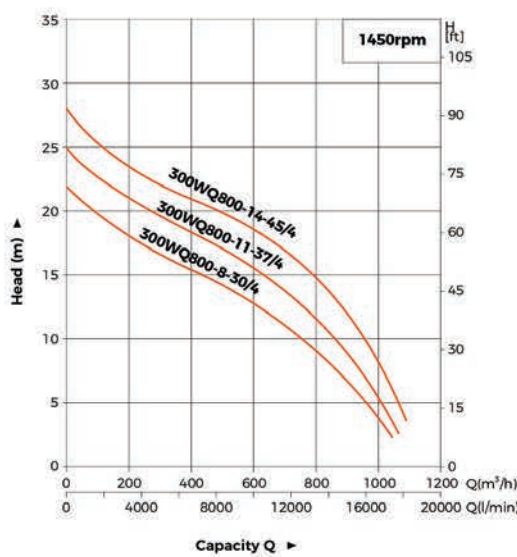
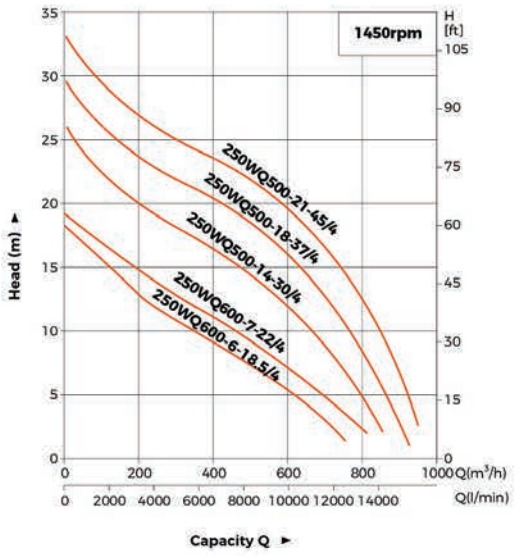
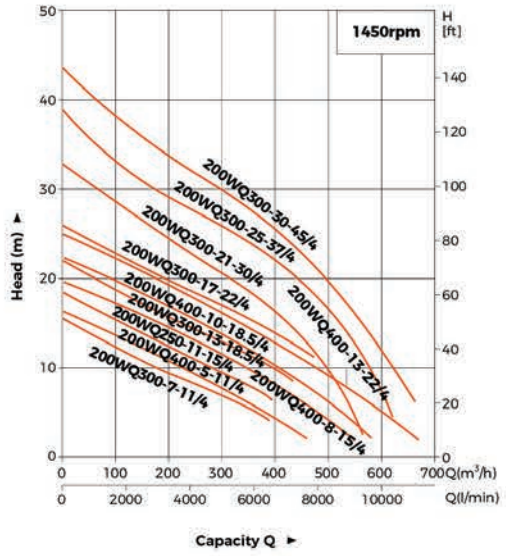

Technical Data

Model	Voltage	Speed	Max. Flow	Max. Head	Motor Power		Discharge	Guide Rlat	Max. Solid Dia	N.W	G.W	Packing Dimension
	V	r.p.m	m³/h	m	kW	HP	in	Fitting	mm	kg	kg	mm
50WQ4-6-0.18M	380	2900	12	7	0.18	0.25	2"	50-50	20	11.2	13.5	414x264x195
50WQD4-6-0.18M(A)	220	2900	12	7	0.18	0.25	2"	50-50	20	11.4	13.7	414x264x195
50WQ5-7-0.25M	380	2900	14	8	0.25	0.33	2"	50-50	20	15.3	22.9	579x235x224
50WQD5-7-0.25M(A)	220	2900	14	8	0.25	0.33	2"	50-50	20	16	23.6	579x235x224
50WQ7-7-0.37M	380	2900	15	10	0.37	0.55	2"	50-50	20	15.4	23.1	579x235x224
50WQD7-7-0.37M(A)	220	2900	15	10	0.37	0.55	2"	50-50	20	16.1	23.7	579x235x224
50WQ6-12-0.55	380	2900	19	15	0.55	0.75	2"	50-50	20	16.5	24.1	579x235x224
50WQD6-12-0.55(A)	220	2900	19	15	0.55	0.75	2"	50-50	20	16.7	24.3	579x235x224
50WQ6-16-0.75	380	2900	22	19	0.75	1	2"	50-50	20	17.2	24.8	579x235x224
50WQD6-16-0.75(A)	220	2900	22	19	0.75	1	2"	50-50	20	17.7	25.3	579x235x224
50WQ10-10-0.75	380	2900	19	15	0.75	1	2"	50-50	20	17	24.6	579x235x224
50WQD10-10-0.75(A)	220	2900	19	15	0.75	1	2"	50-50	20	17.5	25.1	579x235x224
50WQ10-16-1.1	380	2900	30	19	1.1	1.5	2"	50-50	25	29.9	38.6	586x269x261
50WQD10-16-1.1(A)	220	2900	30	19	1.1	1.5	2"	50-50	25	25.6	34.4	586x269x261
50WQ15-10-1.1	380	2900	27	12.5	1.1	1.5	2"	50-50	25	29.5	38.2	586x269x261
50WQD15-10-1.1(A)	220	2900	27	12.5	1.1	1.5	2"	50-50	25	25.2	33.9	586x269x261
65WQ15-10-1.1	380	2900	31.5	13	1.1	1.5	2½"	65-65	25	36.2	48	735x275x340
65WQD15-10-1.1(A)	220	2900	31.5	13	1.1	1.5	2½"	65-65	25	38.6	50.5	735x275x340
50WQ10-20-1.5	380	2900	33	21.5	1.5	2	2"	50-50	25	24.3	33.1	586x269x261
50WQD10-20-1.5	220	2900	33	21.6	1.5	2	2"	50-50	25	25.8	34.6	646x269x261
50WQ15-15-1.5	380	2900	32	18.5	1.5	2	2"	50-50	25	24	32.7	586x269x261
50WQD15-15-1.5	220	2900	32	18.5	1.5	2	2"	50-50	25	25.7	34.5	646x269x261
65WQ15-15-1.5	380	2900	39.7	20	1.5	2	2½"	65-65	25	26.3	35.1	544x269x244
65WQD15-15-1.5	220	2900	39.7	20	1.5	2	2½"	65-65	25	30.1	38.8	604x269x244
50WQ15-20-2.2	380	2900	36	24	2.2	3	2"	50-50	20	30.1	38.8	646x269x261
65WQ15-20-2.2	380	2900	41.6	24.6	2.2	3	2½"	65-65	25	30.7	39.6	604x269x244
80WQ40-9-2.2	380	2900	63	17	2.2	3	3"	80-80	30	31.2	44.9	876x269x261
50WQ18-25-3	380	2900	42	29	3	4	2"	50-50	20	43.4	53	784x324x289
65WQ25-22-3	380	2900	50	29	3	4	2½"	65-65	25	44	55.8	784x324x289
80WQ40-13-3	380	2900	70	20	3	4	3"	80-80	30	44.8	58.7	784x324x289
100WQ60-9-3	380	2900	75	16	3	4	4"	100-100	30	46.8	63.3	784x324x289
50WQ18-32-4	380	2900	45	36	4	5.5	2"	50-50	20	46.2	55.7	784x324x289
65WQ25-28-4	380	2900	51	31.5	4	5.5	2½"	65-65	25	46.8	58.5	784x324x289
80WQ40-18-4	380	2900	79	21	4	5.5	3"	80-80	30	47.4	61.3	784x324x289
100WQ60-13-4	380	2900	85	20	4	5.5	4"	100-100	30	49.6	66.1	784x324x289
50WQ15-40-5.5	380	2900	30	44	5.5	7.5	2"	50-50	20	94	113	430x360x1032
80WQ30-30-5.5	380	2900	70	35	5.5	7.5	3"	80-80	30	93	112.1	954x404x437
80WQ50-15-5.5/4	380	1450	70	25	5.5	7.5	3"	80-80	30	145	173	550x450x1127
100WQ45-22-5.5	380	2900	100	28	5.5	7.5	4"	100-100	30	93	112.1	954x404x437
100WQ65-15-5.5/4	380	1450	120	18	5.5	7.5	4"	100-100	55	145	173.1	1154x549x532
150WQ110-10-5.5/4	380	1450	260	12	5.5	7.5	6"	150-150	75	155	183.1	1154x549x532
50WQ20-45-7.5	380	2900	45	50	7.5	10	2"	50-50	20	108	125	1054x399x439
80WQ30-36-7.5	380	2900	75	41	7.5	10	3"	80-80	30	109	127	1054x399x439
100WQ65-22-7.5	380	2900	108	31	7.5	10	4"	100-100	35	118	137.1	1059x414x469
150WQ100-10-7.5	380	2900	150	20	7.5	10	6"	150-150	35	120	139.1	1059x414x469
80WQ45-22-7.5/4	380	1450	80	26	7.5	10	3"	80-80	30	150	166.8	1127x550x450
100WQ100-15-7.5/4	380	1450	140	21	7.5	10	4"	100-100	55	150	178.1	1154x549x532

Technical Data

Model	Voltage	Speed	Max. Flow	Max. Head	Motor Power	Discharge	Guide Rlat Fitting	Max. Solid Dia	N.W	G.W	Packing Dimension
	V	r.p.m	m ³ /h	m	kW	HP	in	mm	kg	kg	mm
150WQ150-10-7.5/4	380	1450	300	16	7.5	10	6"	150-150	75	160	188.1
50WQ20-55-11	380	2900	45	60.5	11	15	2"	50-50	25	136	156
50WQ30-50-11	380	2900	45	60.5	11	15	2"	50-50	25	136	156
80WQ45-40-11	380	2900	60	50.5	11	15	3"	80-80	30	131	151
80WQ70-30-11	380	2900	100	40.5	11	15	3"	80-80	30	137	157
100WQ80-26-11	380	2900	120	42	11	15	4"	100-100	35	132	152
100WQ100-25-11/4	380	1450	220	31	11	15	4"	100-100	50	252	274
150WQ120-18-11	380	2900	160	30	11	15	6"	150-150	55	137	157
150WQ180-11-11/4	380	1450	260	24	11	15	6"	150-150	60	264	286
200WQ300-7-11/4	380	1450	450	17	11	15	8"	200-200	70	285	314
200WQ400-5-11/4	380	1450	470	18	11	15	8"	200-200	55	285	314
50WQ20-70-15	380	2900	45	75.5	15	20	2"	50-50	25	150	170
50WQ30-65-15	380	2900	45	75.5	15	20	2"	50-50	25	150	170
80WQ70-40-15	380	2900	100	49.5	15	20	3"	80-80	30	149	169
100WQ100-30-15/4	380	1450	220	36	15	20	4"	100-100	50	273	295
150WQ200-15-15/4	380	1450	290	29	15	20	6"	150-150	60	285	307
200WQ250-11-15/4	380	1450	490	21	15	20	8"	200-200	70	305.5	334.5
200WQ400-8-15/4	380	1450	525	19	15	20	8"	200-200	55	304.5	334.5
50WQ20-80-18.5	380	2900	45	85.5	18.5	22	2"	50-50	25	217.5	242.5
50WQ30-75-18.5	380	2900	45	85.5	18.5	22	2"	50-50	25	217.5	242.5
80WQ70-50-18.5	380	2900	100	58.5	18.5	22	3"	80-80	30	212.5	237.5
100WQ100-33-18.5/4	380	1450	220	39	18.5	25	4"	100-100	50	298	320
150WQ150-25-18.5/4	380	1450	300	32	18.5	25	6"	150-150	60	305.5	327.5
200WQ300-13-18.5/4	380	1450	530	25	18.5	25	8"	200-200	70	325.5	354.5
200WQ400-10-18.5/4	380	1450	525	22	18.5	22	8"	200-200	55	325.5	354.5
250WQ600-6-18.5/4	380	1450	750	18	18.5	22	10"	250-250	75	354	383
50WQ20-90-22	380	2900	45	94	22	30	2"	50-50	25	225	250
50WQ30-85-22	380	2900	45	94	22	30	2"	50-50	25	225	250
80WQ70-55-22	380	2900	100	63	22	30	3"	80-80	30	219	244
100WQ100-36-22/4	380	1450	220	42	22	30	4"	100-100	50	293	315
150WQ150-30-22/4	380	1450	330	39	22	30	6"	150-150	60	312	334
200WQ300-17-22/4	380	1450	550	27	22	30	8"	200-200	70	331.5	360.5
200WQ400-13-22/4	380	1450	525	24.5	22	30	8"	200-200	55	331.5	360.5
250WQ600-7-22/4	380	1450	800	22	22	30	10"	250-250	85	360	389
150WQ150-34-30/4	380	1450	310	45	30	40	6"	150-150	55	497	519
200WQ300-21-30/4	380	1450	570	33	30	40	8"	200-200	80	519	541
250WQ500-14-30/4	380	1450	860	27	30	40	10"	250-250	85	512	535
300WQ800-8-30/4	380	1450	1040	22	30	40	12"	300-300	90	557	581
150WQ150-40-37/4	380	1450	330	50	37	50	6"	150-150	55	557	579
200WQ300-25-37/4	380	1450	620	39	37	50	8"	200-200	80	576	598
250WQ500-18-37/4	380	1450	930	30	37	50	10"	250-250	85	570	593
300WQ800-11-37/4	380	1450	1060	25	37	50	12"	300-300	90	614	638
200WQ300-30-45/4	380	1450	660	43	45	60	8"	200-200	80	612	634
250WQ500-21-45/4	380	1450	950	34	45	60	10"	250-250	85	606	629
300WQ800-14-45/4	380	1450	1080	28	45	60	12"	300-300	90	650	674

Dimension

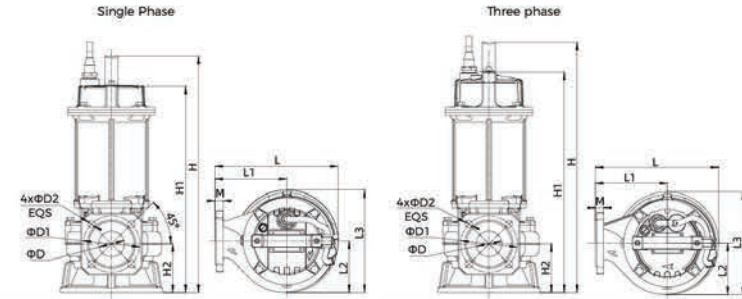

Model	L	L1	L2	L3	M	H	H1	H2	D	D1	D2
50WQ4-6-0.18M	214	120	99	187	16	422	374	81	50	110	14
50WQD4-6-0.18M(A)	214	120	99	187	16	422	374	81	50	110	14
50WQ5-7-0.25M	214	120	99	187	16	422	374	81	50	110	14
50WQD5-7-0.25M(A)	214	120	99	187	16	422	374	81	50	110	14
50WQ7-7-0.37M	214	120	99	187	16	422	374	81	50	110	14
50WQD7-7-0.37M(A)	214	120	99	187	16	422	374	81	50	110	14
50WQ6-12-0.55	214	120	99	187	16	422	374	81	50	110	14
50WQD6-12-0.55(A)	214	120	99	187	16	422	374	81	50	110	14
50WQ6-16-0.75	214	120	99	187	16	422	374	81	50	110	14
50WQD6-16-0.75(A)	214	120	99	187	16	422	374	81	50	110	14
50WQ10-10-0.75	214	120	99	187	16	422	374	81	50	110	14
50WQD10-10-0.75(A)	214	120	99	187	16	422	374	81	50	110	14
50WQ10-16-1.1	240	140	99	200	16	459.5	402	94.5	50	110	14
50WQD10-16-1.1(A)	240	140	99	200	16	487.5	429.5	94.5	50	110	14
50WQ15-10-1.1	240	140	99	200	16	459.5	402	94.5	50	110	14
50WQD15-10-1.1(A)	240	140	99	200	16	487.5	429.5	94.5	50	110	14
65WQ15-10-1.1	240	140	99	200	16	462	404.5	97	65	130	14
65WQD15-10-1.1(A)	240	140	99	200	16	490	432	97	65	130	14
50WQ10-20-1.5	240	140	99	200	16	459.5	402	94.5	50	110	14
50WQD10-20-1.5	240	140	99	200	16	523	465.5	94.5	50	110	14
50WQ15-15-1.5	240	140	99	200	16	459.5	402	94.5	50	110	14
50WQD15-15-1.5	240	140	99	200	16	523	465.5	94.5	50	110	14
65WQ15-15-1.5	240	140	99	200	16	462	404.5	97	65	130	14
65WQD15-15-1.5	240	140	99	200	16	526	468	97	65	130	14
50WQ15-20-2.2	240	140	99	200	16	495.5	438	94.5	50	110	14
65WQ15-20-2.2	240	140	99	200	16	498	440.5	97	65	130	14
80WQ40-9-2.2	240	140	103	203	18	515.5	458	106.5	80	150	19
50WQ18-25-3	289	170	121.5	240	16	530	484	109.5	50	110	14
65WQ25-22-3	289	170	121.5	240	16	530	484	109.5	65	130	14
80WQ40-13-3	289	170	123	242	18	553	507	121.5	80	150	19
100WQ60-9-3	303	180	135	254	18	557	511	125.5	100	170	19
50WQ18-32-4	289	170	121.5	240	16	530	484	109.5	50	110	14
65WQ25-28-4	289	170	121.5	240	16	530	484	109.5	65	130	14
80WQ40-18-4	289	170	123	242	18	553	507	121.5	80	150	19
100WQ60-13-4	303	180	135	254	18	557	511	125.5	100	170	19

Dimension

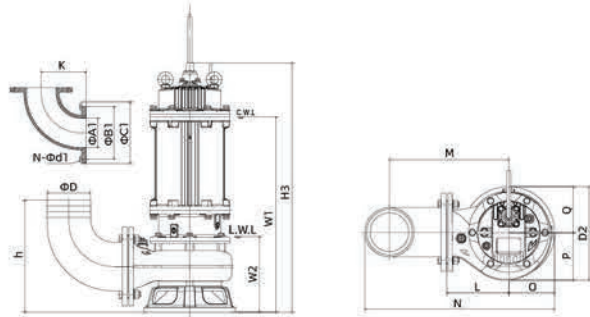

Model	ΦD	ΦA1	ΦB1	ΦC1	N-Φd1	h	W1	W2	H3	K	N	O	P	Q	L	M	D2
80WQ30-30-5.5	80	80	150	190	4-Φ18	332	607	215	735	140	515	136	155	155	200	335	310
100WQ45-22-5.5	100	100	170	210	4-Φ18	315	609	220	744	150	530	155	155	155	200	340	310
50WQ20-45-7.5	50	50	110	140	4-Φ14	284	626	221	777	105	484	133	137.5	200	320	272	284
80WQ30-36-7.5	80	80	150	190	4-Φ18	332	640	215	785	140	520	143	155	155	200	335	310
100WQ65-22-7.5	100	100	170	210	4-Φ18	315	639	220	790	150	530	155	155	155	200	340	310
150WQ100-10-7.5	150	150	225	265	8-Φ18	379	660	241	811	230	640	145	162	155	210	410	317
80WQ45-22-7.5/4	80	80	150	190	4-Φ18	390	679	285	880	155	615	173	179	260	395	349	390
100WQ65-15-5.5/4	100	100	170	210	4-Φ18	390	722	295	873	150	655	187	200	175	280	420	373
100WQ100-15-7.5/4	100	100	170	210	4-Φ18	390	722	295	873	150	655	187	200	175	280	420	373
150WQ110-10-5.5/4	150	150	225	265	8-Φ18	465	756	330	910	230	770	195	217	170	300	500	388
150WQ150-10-7.5/4	150	150	225	265	8-Φ18	465	756	330	910	230	770	195	217	170	300	500	387

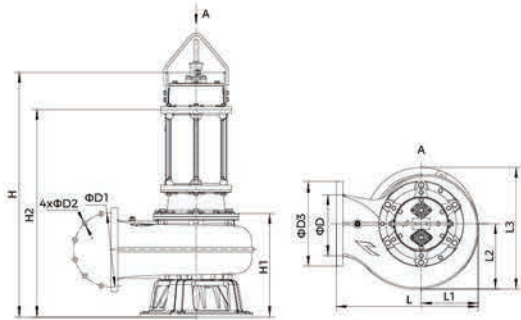

Model	ΦD	ΦD1	ΦD2	ΦD3	H	H1	H2	L	L1	L2	L3
50WQ15-40-5.5	50	110	4-Φ14	165	767	221	597	355	200	155	310
50WQ20-45-7.5	50	150	4-Φ19	200	896	239	715	377	220	147	314
50WQ20-55-11	50	114	4-Φ18	165	854	237	673	372	220	146.5	304
50WQ30-50-11	50	114	4-Φ18	165	854	237	673	372	220	146.5	304
50WQ20-70-15	50	125	4-Φ18	165	894	237	713	372	220	146.5	304
50WQ30-65-15	50	125	4-Φ18	165	894	237	713	372	220	146.5	304
50WQ20-80-18.5	50	114	4-Φ18	165	1106	248	749	419	250	166	340
50WQ30-75-18.5	50	114	4-Φ18	165	1106	248	749	419	250	166	340

Model	ΦD	ΦD1	ΦD2	ΦD3	H	H1	H2	L	L1	L2	L3
50WQ20-90-22	50	114	4-Φ18	165	1106	248	749	419	250	166	340
50WQ30-85-22	50	114	4-Φ18	165	1106	248	749	419	250	166	340
80WQ45-40-11	80	150	4-Φ19	200	842	225	662	355	200	155	310
80WQ70-30-11	80	150	4-Φ19	200	856	239	675	377	220	147	314
80WQ70-40-15	80	150	4-Φ19	200	896	239	715	377	220	147	314
80WQ70-50-18.5	80	150	4-Φ19	200	1112	251	748	386	220	166	333
80WQ70-55-22	80	150	4-Φ19	200	1112	251	748	386	220	166	333
100WQ80-26-11	100	170	4-Φ19	220	850	234	669	200	355	155	310
150WQ120-18-11	150	227.5	8-Φ23	285	871	253	689	210	365	155	317
80WQ50-15-5.5/4	80	150	4-Φ19	200	880	285	698	280	467	172	373
200WQ400-5-11/4	200	283	8-Φ22	340	1176	416	818	623	370	230	514
200WQ400-8-15/4	200	283	8-Φ22	340	1221	416	863	623	370	230	514
200WQ400-10-18.5/4	200	283	8-Φ22	340	1256	416	898	623	370	230	514
200WQ400-13-22/4	200	283	8-Φ22	340	1256	416	898	623	370	230	514
250WQ600-6-18.5/4	250	338	12-Φ22	395	1332	492	974	666	400	265	570
100WQ100-25-11/4	100	170	4-Φ18	210	910	255	650	516	206	217	410
150WQ180-11-11/4	150	225	8-Φ18	265	940	285	680	528	208	225	413
200WQ300-7-11/4	200	295	8-Φ22	340	980	325	720	566	226	253	444
100WQ100-30-15/4	100	170	4-Φ18	210	955	255	695	516	206	217	410
150WQ200-15-15/4	150	225	8-Φ18	265	985	285	725	528	208	225	413
200WQ250-11-15/4	200	295	8-Φ22	340	1025	325	765	566	226	253	444
100WQ100-33-18.5/4	100	170	4-Φ18	210	1010	185	715	543	218	227	433
150WQ150-25-18.5/4	150	225	8-Φ18	265	1035	290	740	556	221	235	441
200WQ300-13-18.5/4	200	295	8-Φ22	340	1080	330	785	583	233	260	463
100WQ100-36-22/4	100	170	4-Φ18	210	1030	265	735	533	218	227	433
150WQ150-30-22/4	150	225	8-Φ18	265	1055	290	760	556	221	235	441
200WQ300-17-22/4	200	295	8-Φ22	340	1100	330	805	583	233	260	463
250WQ600-7-22/4	250	350	12-Φ22	395	1160	400	860	680	280	313	583
150WQ150-34-30/4	150	240	8-Φ22	285	1200	340	855	652	272	283	553
200WQ300-21-30/4	200	295	8-Φ22	340	1240	380	895	676	286	308	578
250WQ500-14-30/4	250	350	12-Φ22	395	1265	400	920	710	300	332	602
300WQ800-8-30/4	300	400	12-Φ22	445	1315	450	970	820	340	386	676
150WQ150-40-37/4	150	240	8-Φ22	285	1255	340	850	652	272	283	553
200WQ300-25-37/4	200	295	8-Φ22	340	1295	380	890	676	286	308	578
250WQ500-18-37/4	250	350	12-Φ22	395	1315	400	910	710	300	332	602
300WQ800-11-37/4	300	400	12-Φ22	445	1365	450	860	820	340	386	676
200WQ300-30-45/4	200	295	8-Φ22	340	1295	380	930	676	286	308	578
250WQ500-21-45/4	250	350	12-Φ22	395	1315	400	950	710	300	332	602
300WQ800-14-45/4	300	400	12-Φ22	445	1365	450	1000	820	340	386	676